

Quotation

	Description
0100-011 MODEL	Metro Star
8012-019 CUSTOMERS / OEMS	Toyne (TOY1000)[1002914]
8011-019 MODEL YEAR	Model Year - 2019
8001-001 COUNTRY OF SERVICE	Country of Service United States Of America
8017-001 CAB AND CHASSIS LABELING LANGUAGE	Cab and Chassis Labeling Language English
8006-011 APPARATUS TYPE	Apparatus Type Rear Mount Quint
8008-001 VEHICLE TYPE	Vehicle Type Straight Truck
8008A-000 VEHICLE ANGLE OF APPROACH PACKAGE	Vehicle Angle of Approach NFPA Minimum 8.00 Degrees
0104-001 AXLE CONFIGURATION	Axle Configuration 4x2 (Rear Axle Drive Only)
0101-010 GROSS AXLE WEIGHT RATINGS FRONT	GAWR Front 22000#
0102-023 GROSS AXLE WEIGHT RATINGS REAR	GAWR Rear 33000#
8010-101 PUMP PROVISION	Pump Provision Driveline Midship w/Auto Park Brake "N"
8009-004 WATER & FOAM TANK CAPACITY	Water & Foam Tank Capacity Up to 750 Gallons
1000-004 CAB STYLE	Cab Style MFD 10" Raised Roof
8101-105 OCCUPANT PROTECTION	Occupant Protection Advanced Protection System
1501-002 CAB FRONT FASCIA	Cab Frt Fascia Classic
1518-025 FRONT GRILLE	Cab Frt Grille Hinged Classic Styled
1551-002 CAB UNDERCOAT	Cab Undercoat
1552-002 CAB SIDE DRIP RAIL	Cab Side Drip Rail
1521-002 CAB PAINT EXTERIOR	Cab Paint Exterior Two Tone
1533-001 CAB PAINT MANUFACTURER	Cab Paint Manufacturer PPG
1522-086 CAB PAINT PRIMARY/LOWER COLOR	Cab Paint Primary/Lower Color PPG Red FBCH 71663
1523-244 CAB PAINT SECONDARY/UPPER COLOR	Cab Paint Sec/Upper Color PPG White FBCH 2185
1524-002 CAB PAINT EXTERIOR BREAKLINE	Cab Paint Exterior Breakline Classic
1515-005 CAB PAINT PINSTRIPE	Cab Paint Pinstripe 1/2" Black Temporary
8013-042 CAB PAINT WARRANTY	Cab Paint Warranty 2019 (10) Year/100,000 Miles
1334-039 CAB PAINT INTERIOR	Cab Paint Int Multi-tone Onyx Blk
1005-001 CAB ENTRY DOORS	Cab Entry Doors (4)
1101-101 CAB ENTRY DOOR TYPE	Cab Entry Door Type Full Length w/Pollak Switches
1322-002 CAB INSULATION	Cab Insulation
1002-009 CAB ROOF TRENCH	Cab Roof Trench 50"W x 10"D
8004-026 CAB STRUCTURAL WARRANTY	Cab Structural Warranty 2019 (10) Year/100,000 Miles
9001-006 CAB TEST INFORMATION	Cab Test Information Crash Test ECE-R29/SAE J2420/SAE J2422
5000-018 ELECTRICAL SYSTEM	Elec System 12V DC Multiplex
5008-058 OEM WIRING	OEM Wir Aerial MUX Harness & Interface
5006-002 APPARATUS WIRING PROVISION	Apparatus Wiring Provision (8) Circuit Panel
5005-201 MULTIPLEX DISPLAY	MUX Display Weldon Vista (2) L/R Sw Pnl
5046-035 MULTIPLEX DISPLAY SPECIAL LAYOUT	Multiplex Display Special Layout Toyne INC
5004-002 LOAD MANAGEMENT SYSTEM	Load Management System Multiplex

5622-003	DATA RECORDING SYSTEM	Data Recording Sys Vehicle Data Weldon MUX
5031-005	ACCESSORY POWER	Accessory Pwr & Gnd Stud 40A Batt Dir & 15A Ign Sw & 225A Batt Dir OEM Conn
5030-061	AUXILIARY ACCESSORY POWER	Aux Acc Pwr & Gnd Stud Frame Mnt Bhd Batt Box 600A Labeled "Aerial EPU" Batt Dir
5032-036	ADDITIONAL ACCESSORY POWER	Addl Acc Pwr 6 Fuse Blue Sea Pnl Eng Tnl Bhd Off Seat w/40A Brkr Batt Dir
5011-001	EXTERIOR ELECTRICAL TERMINAL COATING	Exterior Electrical Terminal Coating Spray On Plasti Dip
1701-158	ENGINE	Engine Diesel 450HP Cummins L9 - EPA 2017
1329-001	CAB ENGINE TUNNEL	Cab Engine Tunnel Small/Medium
1731-002	DIESEL PARTICULATE FILTER CONTROLS	DPF Ctrl Regeneration Sw & Inhibit Sw
1718-002	ENGINE PROGRAMMING HIGH IDLE SPEED	Engine Programming High Idle Speed 1250 RPM
1719-005	ENGINE HIGH IDLE CONTROL	Engine High Idle Ctrl Manual and Automatic w/MUX
1710-001	ENGINE PROGRAMMING ROAD SPEED GOVERNOR	Engine Programming Road Speed Governor Enabled
1713-010	AUXILIARY ENGINE BRAKE	Aux Engine Brake Compression Brake w/VG Turbo
1708-004	AUXILIARY ENGINE BRAKE CONTROL	Aux Engine Brake Ctrl On/Off & Low/Med/High Sw Pnl
1720-003	ELECTRONIC ENGINE OIL LEVEL INDICATOR	Elec Engine Oil Level Indicator
1715-001	FLUID FILLS	Fluid Fills Fwd For Med Displacement Cap
1735-001	ENGINE DRAIN PLUG	Engine Drain Plug
8002-001	ENGINE WARRANTY	Engine Warranty Cummins (5) Year/100,000 Miles
1707-110	REMOTE THROTTLE HARNESS	Rmt Throttle Harness PSG FRC Pump Boss Side Mnt Shift Interlock
1721-001	ENGINE PROGRAMMING REMOTE THROTTLE	Engine Program Rmt Throttle Off
1727-001	ENGINE PROGRAMMING IDLE SPEED	Engine Programming Idle Speed 700 RPM
2704-002	ENGINE FAN DRIVE	Engine Fan Drive Clutch
2701-019	ENGINE COOLING SYSTEM	Engine Cooling Sys Serial Flow Medium/Package Drop-Out Prov/Rwd Sight Glass
2711-005	ENGINE COOLING SYSTEM PROTECTION	Engine Cooling System Protection Light Duty Skid Plate Paint Frame Color
2708-001	ENGINE COOLANT	Engine Coolant Extended Life
2706-003	ELECTRONIC COOLANT LEVEL INDICATOR	Elec Low Coolant Level Indicator
2705-002	ENGINE PUMP HEAT EXCHANGER	Engine Pump Heat Exchanger
2709-004	COOLANT HOSES	Coolant Hoses Silicone Heater & Radiator w/Cab Int Rubber Hoses
2801-009	ENGINE AIR INTAKE	Engine Air Intake Filtration and Restriction w/SS Housing & Replaceable Element
2802-003	AIR INTAKE PROTECTION	Air Intake Protection Light Duty Skid Plate Painted Frame Color
2901-067	ENGINE EXHAUST SYSTEM	Eng Exhaust Sys Under Frm RH Single Module Aftertreatment Outboard
2907-003	DIESEL EXHAUST FLUID TANK	Diesel Exhaust Fluid Tank LH 6 Gal Fill Thru Rr Step
2902-010	ENGINE EXHAUST ACCESSORIES	Engine Exh Acc Exh Temp Mitigation
2906-002	ENGINE EXHAUST WRAP	Engine Exhaust Wrap
1801-015	TRANSMISSION	Transmission Allison 3000 EVS
1806-003	TRANSMISSION MODE PROGRAMMING	Transmission Mode Programming 5th Startup/6th Mode
1811-004	TRANSMISSION FEATURE	Transmission Feature Programming Allison Gen V-E I/O Package

	PROGRAMMING	198/Pumper
1815-002	ELECTRONIC TRANSMISSION OIL LEVEL INDICATOR	Elec Transmission Oil Level Indicator
1807-005	TRANSMISSION SHIFT SELECTOR	Transmission GEN V-E Shift Sel Key Pad/Push Button
1814-002	TRANSMISSION PRE-SELECT WITH AUXILIARY BRAKE	2nd Gear Pre-Select
1808-007	TRANSMISSION COOLING SYSTEM	Transmission Cooling System
1817-001	TRANSMISSION DRAIN PLUG	Transmission Drain Plug
8005-001	TRANSMISSION WARRANTY	Transmission Warranty Allison (5) Year
2004-003	LH PTO	LH PTO Spartan Sply
2001-109	LH PTO MODEL	LH PTO Model Chelsea 280-GGFJP-B5XD
2005-008	PTO LOCATION	PTO Location 8:00/1:00
2015-030	LH PTO CONTROL	LH PTO Ctrl Rkr Enable "Aerial Master"/Rkr Actv "Aerial PTO"
2007-002	PTO PROGRAMMING	PTO Programming Engine Engage 0900/Oper 4000 Transmission Engage 250/Oper 300
3001-001	DRIVELINE	Driveline Spicer 1710
3005-061	MIDSHIP PUMP / GEARBOX	Midship Pump Jackshaft w/Toyne Module Holes
3008-054	MIDSHIP PUMP / GEARBOX MODEL	Midship Pump/Gearbox Model Hale QMAX
3048-005	MIDSHIP PUMP GEARBOX DROP	Midship Pump Gearbox Drop Hale "X"
3009-024	MIDSHIP PUMP RATIO	Midship Pump Ratio 2.32:1 (23)
3010-1210	MIDSHIP PUMP LOCATION C/L SUCTION TO C/L REAR AXLE	Midship Pump Location C/L Suction to C/L Rear Axle 121.0"
3109-060	FUEL FILTER/WATER SEPARATOR	Fuel Filter/Wtr Separator Fleetguard FS1098 w/Lt & Alarm
3111-002	FUEL LINES	Fuel Lines Wire Braid
3104-001	FUEL SHUTOFF VALVE	Fuel Shutoff Valve at Primary Filter
3103-008	ELECTRIC FUEL PRIMER	Electric Fuel Primer Engine Sply Electric Lift Pump
3101-102	FUEL TANK	Fuel Tank 68 Gallon
3130-001	FUEL TANK MATERIAL AND FINISH	Fuel Tank Material Steel & Finish Painted Frame Color
3131-001	FUEL TANK STRAP MATERIAL AND FINISH	Fuel Tank Strap Material Steel & Finish Painted Frame Color
3102-016	FUEL TANK FILL PORT	Fuel Tank Fill Port LH Mid/RH Mid/LH Fwd
3115-002	FUEL TANK DRAIN PLUG	Fuel Tank Drain Plug Magnetic
2401-022	FRONT AXLE	Frt Axle Meritor MFS 23000# Beam
8059-015	FRONT AXLE WARRANTY	Front Axle Warranty Meritor 2019
2405-001	FRONT WHEEL BEARING LUBRICATION	Frt Wheel Bearing Lube Oil
2502-002	FRONT SHOCK ABSORBERS	Frt Shock Absorbers Bilstein
2501-014	FRONT SUSPENSION	Frt Suspension 10 Leaf 23000#
2601-006	STEERING COLUMN/WHEEL	Steering Column/Wheel Tilt/Telescopic 18" 4 Spoke
2609-002	ELECTRONIC POWER STEERING FLUID LEVEL INDICATOR	Elec Power Steering Fluid Level Indicator
2603-011	POWER STEERING PUMP	Power Steering Pump TRW w/Passive Cooler
2606-009	FRONT AXLE CRAMP ANGLE	Front Axle Cramp Angle 48L/44R Degrees
2610-005	POWER STEERING GEAR	Power Steering Gear TRW TAS 85 w/Assist
2608-001	CHASSIS ALIGNMENT	Chassis Alignment
3401-014	REAR AXLE	Rear Axle 33000# Meritor RS-30-185
3403-001	REAR AXLE DIFFERENTIAL	Rear Axle Differential Lubrication Oil

LUBRICATION

8061-012	REAR AXLE WARRANTY	Rear Axle Warranty Meritor 2019
3411-001	REAR WHEEL BEARING LUBRICATION	Rear Wheel Bearing Lubrication Oil
3407-002	REAR AXLE DIFFERENTIAL CONTROL	Rear Axle Differential Ctrl DCDL
3408-003	VEHICLE TOP SPEED	Vehicle Top Speed 60 MPH
3501G-001	REAR SUSPENSION AUX SPRING	REAR SUSPENSION AUX SPRING
3501-001	REAR SUSPENSION	Rear Susp Reyco 79KB Spring 21000-33000# w/Helper
3601-037	FRONT TIRE	Frnt Tire 425/65R 22.5 Goodyear G296 MSA
3602-062	REAR TIRE	Rear Tire 315/80R 22.5 Goodyear G751 MSA
3413-614	REAR AXLE RATIO	Rear Axle Ratio 6.14
3614-030	TIRE PRESSURE INDICATOR	Tire Pressure Ind Frnt & Rr LED
3701-016	FRONT WHEEL	Frnt Wheel Accuride 22.5 x 12.25 Alum
3703-013	REAR WHEEL	Rr Whl Accuride 22.5 x 9.00 Alum
3702-002	WHEEL TRIM	Wheel Trim Hub & Nut Covers SS Shiploose
3725-003	WHEEL GUARDS	Wheel Guards Between Dual Wheels & All Axles
3205-014	BRAKE SYSTEM	Brake System ABS/ATC/ESC Sgl Axle MUX Btn
3206-003	FRONT BRAKES	Frnt Brakes Meritor EX225 Disc 17"
3207-009	REAR BRAKES	Rr Brakes S-Cam Drum 16.5" x 8.6" Cast Iron Shoe
3208-001	PARK BRAKE	Prk Brake Rr Wheels Only
3219-002	SUPPLEMENTAL BRAKE	Supplemental Brake Frnt Service Brakes Prk Brk Actv
3204-002	PARK BRAKE CONTROL	Prk Brake Ctrl Ctr Tunnel Mnt
3214-002	REAR BRAKE SLACK ADJUSTERS	Rr Brake Slack Adjusters Haldex
3202-015	AIR DRYER	Air Dryer Wabco System Saver 1200 Bhd LH Batt Box Outboard/Aerial Brkt
3215-004	FRONT BRAKE CHAMBERS	Frnt Brake Chambers MGM Type 24 Long Stroke
3210-015	REAR BRAKE CHAMBERS	Rr Brake Chambers TSE 30/36 Long Stroke
3320-001	AIR COMPRESSOR	Air Compressor Wabco SS318 18.7 CFM
3339-004	AIR GOVERNOR	Air Governor Mnt on Air Dryer Bracket
3303-007	MOISTURE EJECTORS	Moisture Ejectors Manual/Auto Htd Wet Tank
3307-001	AIR SUPPLY LINES	Air Sply Lines Nylon
3334-002	AIR TANK SPACERS	Air Tank Spacers Inboard 1.5"
2103-2090	WHEELBASE	Wheelbase 209.0"
2106-1090	REAR OVERHANG	Rear Overhang 109.0"
2101-002	FRAME	Frame Double Channel 35.00" Width
8007-024	FRAME WARRANTY	Frame Warranty Lifetime 2019
2111-122	MISC FRAME OPTIONS	Misc Frame Options Toyne Pumper Body Mnt Hole Pattern #4
2117-004	FRAME CLEAR AREA	Frame Clear Area Inside/Outside Rail 30" Rwd Back of Cab
2110-201	FRAME PAINT	Frame Paint Hot Dipped Galvanized - Frame Only Addl Comp Blk Powder Coat
2201-001	FRONT BUMPER	Frnt Bumper Stainless Steel Flat
2202-006	FRONT BUMPER EXTENSION LENGTH	Frnt Bumper Extension Length 24"
2215-002	FRONT BUMPER SUCTION PROVISION	Frnt Bumper Suction Provision 5.0" RH Vertical Outboard
2208-007	FRONT BUMPER APRON	Frnt Bumper Apron For 24" Extension
2237-004	FRONT BUMPER DISCHARGE	Front Bumper Discharge 2.0" LH Frame Mnt Plumbing

2211-024	FRONT BUMPER COMPARTMENT CENTER	Frnt Bumper Cmpt Ctr w/Notched Cover
2210-002	FRONT BUMPER COMPARTMENT COVER HARDWARE	Frnt Bumper Cmpt Cover Hardware Gas Cylinder/D-ring
5503-022	MECHANICAL SIREN	Mechanical Siren Federal Signal Q2B Pedestal Mnt
2218-002	MECHANICAL SIREN LOCATION	Mech Siren Location Frnt Bmpr Apron LH OB
5501-012	AIR HORN	Air Horn (2) 24" Round Hadley E-Tone
2216-004	AIR HORN LOCATION	Air Horn Location (2) Frnt Bmpr Face LH
2232-002	AIR HORN RESERVOIR	Air Horn Reservoir (1) 1200 Cu In
5504-029	ELECTRONIC SIREN SPEAKER	Elect Siren Speaker 100W Cast Products SA4301
2217-005	ELECTRONIC SIREN SPEAKER LOCATION	Elec Siren Speaker Location Frnt Bmpr Face RH OB
2203-001	FRONT BUMPER TOW HOOKS	Frnt Bumper Tow Hooks Chrome Below Fwd
2301-001	CAB TILT SYSTEM	Cab Tilt System
2303-002	CAB TILT LIMIT SWITCH	Cab Tilt Limit Sw
2305-012	CAB TILT CONTROL RECEPTACLE	Cab Tilt Ctrl Receptacle Temp w/10' Extended Cable
2306-002	CAB TILT LOCK DOWN INDICATOR	Cab Tilt Lock Down Indicator
1401-009	CAB WINDSHIELD	Cab Windshield
1402-005	GLASS FRONT DOOR	Glass Frnt Dr Roll Down/XDuty Regulator
1407-001	GLASS TINT FRONT DOOR	Glass Tint Frnt Dr Automotive Green
1419-012	GLASS REAR DOOR RIGHT HAND	Glass Rr Dr RH Roll Down/XDuty Regulator
1430-001	GLASS TINT REAR DOOR RIGHT HAND	Glass Tint Rr Door RH Automotive Green
1412-013	GLASS REAR DOOR LEFT HAND	Glass Rr Dr LH Roll Down/XDuty Regulator
1431-001	GLASS TINT REAR DOOR LEFT HAND	Glass Tint Rr Door LH Automotive Green
1410-003	GLASS SIDE MID RIGHT HAND	Glass Side Mid RH Fxd 16"W x 26"H
1432-001	GLASS TINT SIDE MID RIGHT HAND	Glass Tint Side Mid RH Automotive Green
1409-003	GLASS SIDE MID LEFT HAND	Glass Side Mid LH Fxd 16"W x 26"H
1433-001	GLASS TINT SIDE MID LEFT HAND	Glass Tint Side Mid LH Automotive Green
1614-202	CLIMATE CONTROL	Climate Ctrl Htr Defroster A/C SGM Ovrhd Alum
1632-002	CLIMATE CONTROL DRAIN	Climate Control Drain Gravity
1617-110	CLIMATE CONTROL ACTIVATION	Climate Ctrl Actv Rotary Dash Mnt Ctr Lwr Ctr
1620-019	HVAC OVERHEAD COVER PAINT	HVAC Overhead Cover Paint Multi-tone Onyx Black
1603-002	A/C CONDENSER LOCATION	A/C Condenser Location Roof Mnt Mid LH
1601-013	A/C COMPRESSOR	A/C Compressor TM-31/QP-31
1530-001	UNDER CAB INSULATION	Under Cab Insulation Engine Tunnel
1327-001	INTERIOR TRIM FLOOR	Interior Trim Floor
1302-001	INTERIOR TRIM	Interior Trim Vinyl
1368-003	REAR WALL INTERIOR TRIM	Rear Wall Interior Trim Painted Aluminum
1306-006	HEADER TRIM	Header Trim XDuty
1305-016	TRIM CENTER DASH	Trim Center Dash XDuty Deluxe w/Gas Cylinder Stay
1339-102	TRIM LEFT HAND DASH	Trim LH Dash XDuty
1321-004	TRIM RIGHT HAND DASH	Trim RH Dash XDuty Glove Cmpt/MDT Prov
1307-002	ENGINE TUNNEL TRIM	Eng Tnl Trim Flr Mat
5040-101	POWER POINT DASH MOUNT	Pwr Pnt Dash Mnt Batt Dir (1) Sw Pnl/(2) Dual USB Blue Sea 2.1A Sw Pnl

1303-017	STEP TRIM	Step Trim Grip Strut Lwr Flex-Tred Mid
1336-002	STEP TRIM KICKPLATE	Step Trim Kickplate Treadplate
1379-003	UNDER CAB ACCESS DOOR	Under Cab Access Door Rear Step LH Painted
1102-013	INTERIOR DOOR TRIM	Interior Door Trim Painted
1323-001	DOOR TRIM CUSTOMER NAMEPLATE	Door Trim Customer Nameplate
1105-001	CAB DOOR TRIM REFLECTIVE	Cab Dr Trim Reflective Vert Stripe/6" Chevron w/Logo
1308-001	INTERIOR GRAB HANDLE "A" PILLAR	Interior Grab Handle 'A' Pillar 11" Molded
1332-008	INTERIOR GRAB HANDLE FRONT DOOR	Interior Grab Handle Frt Door Horiz 9"
1345-002	INTERIOR GRAB HANDLE REAR DOOR	Int Grab Handle Rr Dr Alum Window Span 30" Black Powder Coat
1301-001	INTERIOR SOFT TRIM COLOR	Interior Soft Trim Color Black
1337-004	INTERIOR TRIM SUNVISOR	Interior Trim Sunvisor Vinyl Black
1304-002	INTERIOR FLOOR MAT COLOR	Interior Floor Mat Color Black
1335-018	CAB PAINT INTERIOR DOOR TRIM	Cab Paint Int Dr Trim Multi-tone Onyx Black
1371-021	HEADER TRIM INTERIOR PAINT	Header Trim Interior Paint Multi-tone Onyx Black
1370-023	TRIM CENTER DASH INTERIOR PAINT	Trim Center Dash Interior Paint Multi-tone Onyx Black
1378-022	TRIM LEFT HAND DASH INTERIOR PAINT	Trim LH Dash Interior Paint Multi-tone Onyx Black
1373-022	TRIM RIGHT HAND DASH INTERIOR PAINT	Trim RH Dash Interior Paint Multi-tone Onyx Black
1369-018	REAR WALL INTERIOR PAINT	Rear Wall Interior Paint Multi-tone Onyx Black
1344-002	DASH PANEL GROUP	Dash Pnl Group 3-Pnl
1312-002	SWITCHES CENTER PANEL	Switches Ctr Pnl 6 Upr LH
1313-002	SWITCHES LEFT PANEL	Switches Left Pnl 1 Wiper
1314-001	SWITCHES RIGHT PANEL	Switches Right Pnl 0
1225-007	SEAT BELT WARNING	Seat Belt Warn Vista Display w/VDR
1237-005	SEAT MATERIAL	Seat Material Durawear Plus
1243-003	SEAT COLOR	Seat Color Black/Red Seat Belts
1249-126	SEAT BACK LOGO	Seat Back Logo Toyne
1201-033	SEAT DRIVER	Seat Driver Bostrom Firefighter 8-Way Elect 500 Series ABTS
1213-025	SEAT BACK DRIVER	Seat Back Driver Non-SCBA ABTS
1219-001	SEAT MOUNTING DRIVER	Seat Mounting Driver
8102-103	OCCUPANT PROTECTION DRIVER	Occupant Protection Driver Advanced Protection System
1202-037	SEAT OFFICER	Seat Officer Bostrom Firefighter Fixed 500 Series ABTS
1214-034	SEAT BACK OFFICER	Seat Back Officer SCBA IMMI SmartDock
1220-002	SEAT MOUNTING OFFICER	Seat Mounting Officer
8103-103	OCCUPANT PROTECTION OFFICER	Occupant Protection Officer Advanced Protection System
1297-002	POWER SEAT WIRING	Power Seats Wiring Battery Direct
1273-001	SEAT BELT ORIENTATION CREW	Seat Belt Orientation Crew Outboard Shoulder To Inboard Hip
1263-001	SEAT REAR FACING OUTER LOCATION	Seat RFO Location (2) R/L
1203-020	SEAT CREW REAR FACING OUTER	Seat Crew RFO Bostrom Firefighter Fixed 500 Series
1215-031	SEAT BACK REAR FACING OUTER	Seat Back RFO SCBA IMMI SmartDock
1221-009	SEAT MOUNTING REAR FACING OUTER	Seat Mounting RFO Rwd 2"
8104-103	OCCUPANT PROTECTION RFO	Occupant Protection RFO Advanced Protection System
1266-001	SEAT FORWARD FACING CENTER LOCATION	Seat FFC Location (2) Ctr

1206-031	SEAT CREW FORWARD FACING CENTER	Seat Crew FFC Bostrom Firefighter Fold & Hold Flip-Up 500 Series
1218-035	SEAT BACK FORWARD FACING CENTER	Seat Back FFC SCBA IMMI SmartDock
8107-102	OCCUPANT PROTECTION FFC	Occupant Protection FFC Advanced Protection System
1269-101	SEAT FRAME FORWARD FACING	Seat Frm Fwd Fcg Dual
1281-101	SEAT FRAME FORWARD FACING STORAGE ACCESS	Seat Frm Fwd Fcg Strg Acc Dr (2) R/L Sd
1224-002	SEAT MOUNTING FORWARD FACING CENTER	Seat Mounting Forward Facing Center
1311-101	CAB FRONT UNDERSEAT STORAGE ACCESS DOOR	Cab Frt Undrst Strg Acc Dr
1355-023	SEAT COMPARTMENT DOOR FINISH	Seat Compartment Door Finish Multi-tone Onyx Black
1511-100	WINDSHIELD WIPER SYSTEM	Windshield Wiper System
1534-002	ELECTRONIC WINDSHIELD FLUID LEVEL INDICATOR	Electronic Windshield Fluid Level Indicator
1103-002	CAB DOOR HARDWARE	Cab Door Hardware Black
1111-001	DOOR LOCKS	Door Locks Manual
1503-002	GRAB HANDLES	Grab Handles SS 18"
1504-014	REARVIEW MIRRORS	Mirror Aerodynamic Retrac 613305 Rmt Htd
1529-003	REARVIEW MIRROR HEAT SWITCH	Rearview Mirror Heat Sw MUX
1525-002	EXTERIOR TRIM REAR CORNER	Exterior Trim Rear Corner Scuff Plate
1513-010	CAB FENDER	Cab Fender Alum Wide
1514-002	MUD FLAPS FRONT	Mud Flaps Frt
1526-027	CAB EXTERIOR FRONT & SIDE EMBLEMS	Cab Ext Frt & Side Emblems Spartan w/APS
5109-001	IGNITION	Ign Mstr Sw w/Keyless Start
5101-017	BATTERY	Batt (6) Group 31 Napa 7236
5106-003	BATTERY TRAY	Batt Tray (2) R/L Steel
5107-007	BATTERY BOX COVER	Batt Box Cover (2) Steel w/Black Handles
5102-001	BATTERY CABLE	Batt Cables
5108-002	BATTERY JUMPER STUD	Batt Jumper Stud Frt LH Lwr Step
5104-002	ALTERNATOR	Alternator Leece-Neville 320A
5105-001	STARTER MOTOR	Starter Motor Delco
5202-075	BATTERY CONDITIONER	Batt Cond Kussmaul Auto Charge 40 LPC LH RFO Seat Position
5203-002	BATTERY CONDITIONER DISPLAY	Batt Cond Display LH Mid Glass
3314-006	AUXILIARY AIR COMPRESSOR	Aux Air Cmp Kussmaul Auto Pump 120V Bhd Off Seat Mnt Horiz
5204-055	ELECTRICAL INLET	Elec Inlet 120V 20A Auto Eject
5209-002	ELECTRICAL INLET LOCATION	Elec Inlet Location LH Cab Side Mid
5210-005	ELECTRICAL INLET CONNECTION	Elec Inlet Conn to Batt Conditioner & Air Pump
5206-002	ELECTRICAL INLET COLOR	Elec Inlet Color Yellow
5301-102	HEADLIGHTS	Headlights 4 Headlamps LED
5303-004	FRONT TURN SIGNALS	Frt Turn Signals Whelen 600 LED
5337-002	HEADLIGHT LOCATION	Headlights Above Frt Warn Lts
5336-003	SIDE TURN/MARKER LIGHTS	Side Turn/Marker Lts LED
5302-003	MARKER & ICC LIGHTS	Marker & ICC Lts Face Mnt LED
5350-060	HEADLIGHT AND MARKER LIGHT ACTIVATION	Hdlt & Mrkr Lt Actv MUX/DRL

5308-011	GROUND LIGHTS	Ground Lts LED Resp Side Dr, Prk Brk Sw & Vista
5309-003	LOWER CAB STEP LIGHTS	Lwr Cab Step Lts LED
5382-002	INTERMEDIATE STEP LIGHTS	Intermediate Step Lts LED
5312-003	ENGINE COMPARTMENT LIGHT	Engine Cmpt Work Lt LED (1)
5403-051	LIGHTBAR PROVISION	Lightbar Prov Wire & Mnt (2) Spartan Supply
5450-255	CAB FRONT LIGHTBAR	Cab Frt Ltbar Whelen Freedom F4NMINI (2) 3R2C 30-Deg Mnt Layout 1
5426-003	LIGHTBAR SWITCH	Lightbar Sw Vista
5317-194	FRONT SCENE LIGHTS	Frt Scene Lts Whelen Pioneer 12V LED PFH1 (2)
5335-003	FRONT SCENE LIGHTS ACTIVATION	Frt Scene Lts Actv Vista
5329-006	FRONT SCENE LIGHT LOCATION	Frt Scene Lt Loc (2) Outboard Brow Pos
5306-065	SIDE SCENE LIGHTS	Side Scene Lts Whelen 900 12V Super 24 LED Clear Gradient
5318-004	SIDE SCENE LIGHT LOCATION	Side Scene Lt Loc Upper Mid Rwd 10" Roof Position
5316-007	SIDE SCENE ACTIVATION	Side Scene Actv Indv Vista Buttons
5305-157	INTERIOR OVERHEAD LIGHTS	Interior Overhead Lts Weldon LED w/Front Map Lts/MUX Actv
5406-076	DO NOT MOVE APPARATUS LIGHT	Do Not Move App Lt Flashing Red Whelen Ion LED w/Alarm
5422-002	MASTER WARNING SWITCH	Mstr Warn Sw MUX
5409-002	HEADLIGHT FLASHER	Headlight Flasher Alternating
5425-003	HEADLIGHT FLASHER SWITCH	Headlight Flasher Sw MUX
5401-032	INBOARD FRONT WARNING LIGHTS	Inboard Frt Warn Lts Whelen M6 LED Chrm Bezel
5413-002	INBOARD FRONT WARNING LIGHTS COLOR	Inboard Frt Warn Lts Color Red
5423-003	FRONT WARNING SWITCH	Frt Warn Sw Vista
5404-027	INTERSECTION WARNING LIGHTS	Intersection Warn Lts Whelen M6 Super LED
5419-002	INTERSECTION WARNING LIGHTS COLOR	Int Warn Lts Color Red
5420-002	INTERSECTION WARNING LIGHTS LOCATION	Intersection Warn Lts Location Bumper Tail Rwd
5402-029	SIDE WARNING LIGHTS	Side Warn Lts Whelen M6 Super LED
5418-002	SIDE WARNING LIGHTS COLOR	Side Warn Lts Color Red
5412-002	SIDE WARNING LIGHTS LOCATION	Side Warn Lts Location Lwr Mid
5424-003	SIDE AND INTERSECTION WARNING SWITCH	Side & Intersection Warn Sw Vista
5510-004	SIREN CONTROL HEAD	Siren Ctrl Head Whelen 295HFS2
5512-013	AIR HORN ACTIVATION	Air Horn Actv L/R Lanyard
5513-014	MECHANICAL SIREN ACTIVATION	Mech Siren Actv R/L Ft Sw/Brk Sw MUX
5505-002	BACK-UP ALARM	Back-Up Alarm Ecco 575
5601-041	INSTRUMENTATION	Instrumentation Standard
5624-001	BACKLIGHTING COLOR	Backlighting Color Red
5607-016	HOUR METER	Hour Meter Honeywell in Instrument Pnl for LH PTO Labeled "Aerial Hours"
5701-056	RADIO	Radio Jensen WB/AM/FM/CD/iPod/Sat Ovrhd LH
5707-002	AM/FM ANTENNA	AM/FM Antenna LH Fwd Cab Roof
5706-005	CAMERA	Cam Rr Box on (2) Vistas
5703-011	COMMUNICATION ANTENNA	Comm Ant Base LH Fwd Cab Rf Spartan Sply
5708-002	COMMUNICATION ANTENNA CABLE	Comm Ant Cable Routing Under RH Frt Seat

ROUTING

5709-002	AUXILIARY COMMUNICATION ANTENNA	Aux Comm Ant Base RH Fwd Cab Roof Spartan Sply
5710-003	AUXILIARY COMMUNICATION ANTENNA CABLE ROUTING	Aux Comm Ant Cable Routing Under Rkr Sw Pnl
5702-023	TWO-WAY RADIOS	Two-Way Radio Exterior Conduit to Under RH Seat
5020-001	PANEL LAYOUT	Panel Layout
8814-002	CAB EXTERIOR PROTECTION	Cab Exterior Protection Front
8806-001	FIRE EXTINGUISHER	Fire Extinguisher Shiploose
8807-002	ROAD SAFETY KIT	Road Safety Kit Shiploose
8810-001	DOOR KEYS	Door Keys for Manual Locks (4)
8811-003	DIAGNOSTIC SOFTWARE OCCUPANT PROTECTION	Diagnostic Software Occupant Protection Advanced Protection System
8003-155	WARRANTY	Warranty Cab and Chassis 2019 (2) Year
8030-006	CHASSIS OPERATION MANUAL	Chassis Operation Manual Digital Copy (2)
8031-024	ENGINE & TRANSMISSION OPERATION MANUAL	Eng & Trans Operation Man Eng Hard Copy/Trans Digital/Eng Owner Digital
8805-007	CAB/CHASSIS AS BUILT WIRING DIAGRAMS	Cab/Chassis As Built Wiring Diagrams Digital Copy (2)
8039-001	SALES TERMS	Sales Terms
9005-002	DRIVELINE LAYOUT CONFIRMATION	Driveline Layout Confirmation Required
9006-002	3D CHASSIS LAYOUT	3D Chassis Layout Required
2124-002	EFCM/REAR CROSSMEMBERS	End of Frame Cross Member

Panel Visual Layout

5020-001 Panel Layout

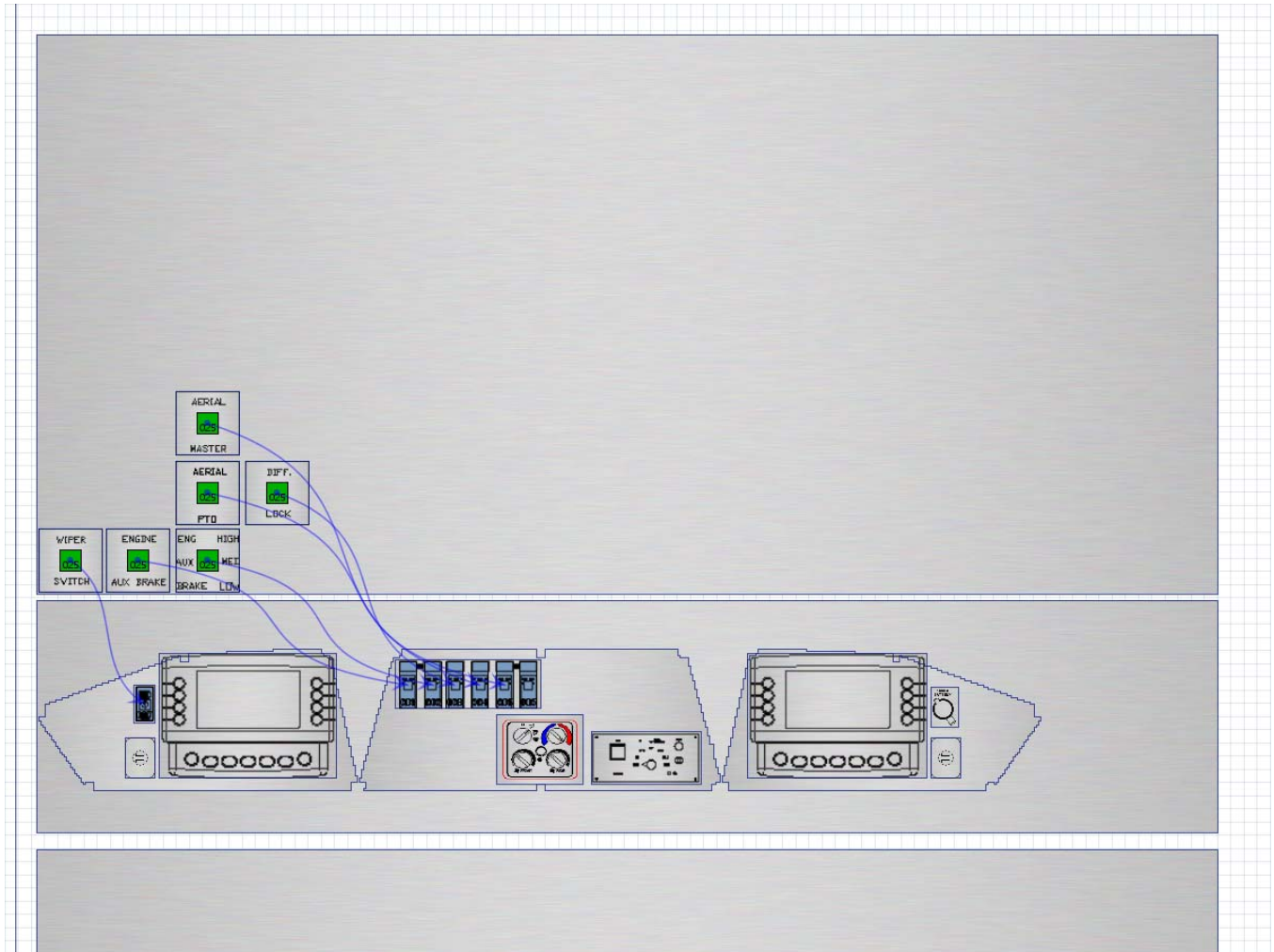

Weight Distribution

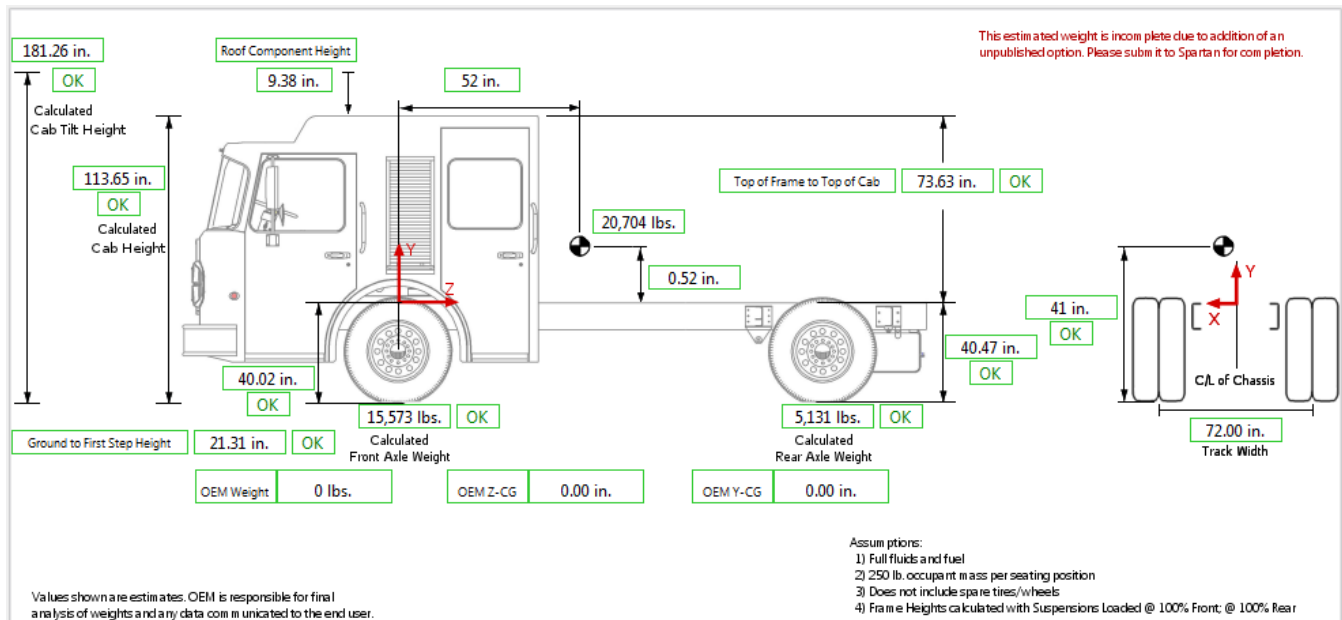

Calculated Apparatus Weight 20,704 lbs.
 Calculated Apparatus Z-CG 52 in.
 Calculated Apparatus Y-CG 0.52 in.

Note:

The Y-CG value above is calculated from the top of the frame.
 Apparatus refers to total combined value for cab and chassis and OEM inputs.

Frame Dimensions

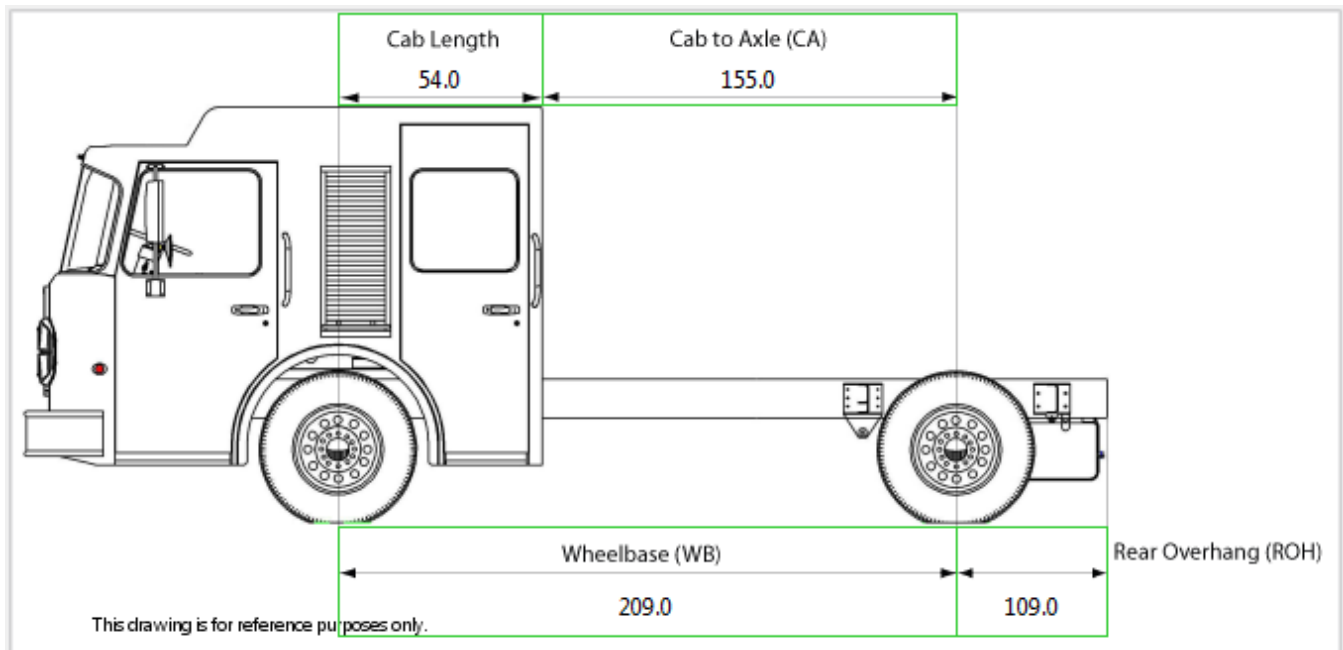

Toyne Inc.

== 75' Aerial Ladder, 500# Tip, OEM - 10.800 01/19/18 ==

00-10-1000

AERIAL TESTING & CERTIFICATION

General

The following Apparatus shall comply with all (NFPA) 1901, Standard for Automotive Fire Apparatus, applicable regulations in effect as of the contract signing date. There shall be multiple tests performed by the contractor and Underwriter's Laboratories, LLC when the apparatus has been completed. The manufacturer shall furnish the completed Test Certificate(s) to the purchaser at time of delivery.

The apparatus upon completion will be tested and certified by Underwriters Laboratories, LLC The certification tests will follow the guide lines outlined in (NFPA) 1901, Standard for Automotive Fire Apparatus.

There shall be multiple tests performed by the contractor and Underwriter's Laboratories, LLC when the apparatus has been completed. The manufacturer shall provide the completed Test Certificate(s) to the purchaser at time of delivery. The inspection services of Underwriters Laboratories, LLC are available to all bidders on an equal basis; therefore, no third party testing service shall be acceptable.

Performance Testing

All work outlined in (NFPA) 1901, Standard for Automotive Fire Apparatus, including nondestructive testing, shall be conducted at the manufacturer's facility. In addition, the following test work, Certification Test sections of (NFPA) 1901, Standard for Automotive Fire Apparatus, shall be conducted.

1. 1-1/2:1 DYNAMIC STABILITY AND LIFT TEST - A test of the apparatus shall be performed that the ladder sections are so designed and powered to support a load representing 150% of the manufacturer's rated tip load capacity at maximum horizontal reach on level ground. Since this is a dynamic test, the load must be raised, lowered and rotated without evidence of instability.

2. 1-1/3:1 DYNAMIC STABILITY AND LIFT TEST - A test of the apparatus shall be performed that the tip and ladder sections are so designed and powered to support a load representing 133% of the manufacturer's rated tip load capacity at maximum horizontal reach on a five (5) degree slope. Since this is a dynamic test, the load must be raised, lowered and rotated without evidence of instability.

Toyne Inc.

3. TIME TEST - A test of the apparatus shall be performed to raise the ladder from a bedded position extended to full height and rotated through a 90 degree turn smoothly and without undue vibration in not over 120 seconds.

4. WATER TOWER TEST #1 - A test of the apparatus shall be performed to test its ability to discharge 1000 gallons per minute parallel to the ladder with the unit at full extension and zero degree elevation. The unit shall be capable of performing this test while loaded to its rated tip load capacity.

5. WATER TOWER TEST #2 - A test of the apparatus shall be performed to test the ability to discharge 1000 gallons per minute, 90 to the ladder with the ladder at full extension, zero degree elevation. The unit shall be capable of performing this test while loaded to its rated tip load capacity.

Bidders must state their ability to comply with all of the above tests. Failure to do so shall be grounds for rejection of their bid.

Written Examination and Test Report

A complete written Examination and Test Report for each aerial device inspection performed at the manufacturer's facility. The test report, as required by (NFPA) 1901, Standard for Automotive Fire Apparatus, shall include the following test results.

a). Torque verification of all mounting bolts including bolt size, grade, and torque specification.

b). The following NDT methods and results shall be recorded. All ferrous welds shall be magnetic particle inspected for defects. All nonferrous welds shall be visually inspected, and if questionable defect are identified, a penetrating dye shall be used to further evaluate the quality of the weld. All bolts and pins shall be ultrasonically inspected for internal flaws. A waterway pressure test shall be performed and a hydraulic oil sample taken.

c). The following measurements shall be taken and recorded in the examination and test record: bearing clearance and backlash, elevation cylinder drift, engine speed operating rpm, relief pressure, stabilizer extension cylinder drift, ladder section twist, hardness readings, base rail thickness, winch drift, extension brake drift, and extension cylinder drift.

Personnel

The inspectors performing the test work on the units are certified to Level II in the required NDT methods, under the requirements outlined in ASNT document CP-189.

Toyne Inc.

Aerial Apparatus Certification

When the unit successfully meets all the requirements outlined in (NFPA) 1901, Standard for Automotive Fire Apparatus, UL, LLC shall issue a Certificate of Automotive Fire Apparatus Examination and Test stating the unit's compliance with (NFPA) 1901, Standard for Automotive Fire Apparatus.

00-13-1000

MANUALS

The aerial manufacturer shall provide the following manuals pertaining to the aerial device:

Two (2): Operators' manuals.

Two (2): Parts manuals in a CD format.

Two (2): Electrical and Hydraulic Diagrams in a CD format.

00-37-1000

WARNING/INFORMATION LABELS

Warning and information labels shall be provided in appropriate locations to alert the operator of potential hazards and operating instructions. All warning labels shall be in compliance with (NFPA) 1901, Standard for Automotive Fire Apparatus.

00-38-1000

ON-SITE PREVENTATIVE MAINTENANCE & OPERATIONAL TRAINING

PROGRAM OUTLINE

An on-site program for demonstration and instruction of the Fire Department personnel shall be provided. This program shall be designed to assure complete understanding of all aspects of the aerial device in the operating environment.

After the unit has been accepted, a factory trained, qualified Field Service Technician shall be provided for a minimum of three (3) consecutive days of instruction.

The program shall be designed to instruct an individual who has never utilized an aerial device of this type before. The individual shall be thoroughly taught the operating systems of the aerial device, including emergency operation. Introductory service skills utilizing the vehicle shall also be taught.

OPERATION & MAINTENANCE PROGRAM

Toyne Inc.

To instruct Fire Department personnel in the operation, preventative maintenance and care of the aerial device, this instruction program shall be oriented towards a hands-on approach utilizing the new apparatus.

1. Explain operations of the entire aerial device. Each participant shall actually use the aerial and be instructed in the necessary steps of safe operation.
2. Troubleshooting shall be emphasized and reinforced continually throughout the instruction period.
3. Preventative maintenance procedures shall be setup and definite schedules developed to assure proper maintenance of the aerial device.
4. Instruction in the use of tools and how to replace minor assemblies, as applicable. Equally important in this instruction shall be when to call appropriate personnel for assistance.
5. How to order parts through the local service center by utilizing parts manual.

00-61-1000

WARRANTY - AERIAL DEVICE

The aerial device manufacturer shall guarantee to the original purchaser to repair or replace any defective structural component resulting from faulty material or workmanship for a period of twenty (20) years after delivery of the aerial device to the purchaser. The warranty shall cover the aerial ladder weldments, open base, torque box and outrigger weldments.

To ensure sole source responsibility of the aerial device, the bidder shall clearly state its intention to warrant the aerial ladder, open base, torque box and outrigger weldments as these integral parts and components of the aerial device.

WARRANTY - AERIAL DEVICE COMPONENTS

The manufacturer of the aerial device shall guarantee to the purchaser to repair or replace any defective or prematurely failed parts, resulting from faulty material or workmanship, for a period of two (2) years after delivery of the aerial device to the purchaser.

WARRANTY - HYDRAULIC CYLINDERS

The manufacturer of the aerial device shall guarantee to the purchaser to repair or replace any defective or prematurely failed parts, resulting from faulty material or workmanship, for a period of two (2) years after delivery of the aerial device to the purchaser.

Toyne Inc.

WARRANTY - HYDRAULIC CYLINDER STRUCTURAL

The manufacturer of the aerial device shall guarantee to the purchaser to repair or replace any defective or prematurely failed parts, resulting from structural defects or failures, for a period of five (5) years after delivery of the aerial device to the purchaser.

WARRANTY - HYDRAULIC CYLINDER SEALS

The manufacturer of the aerial device shall also guarantee the cylinder seals to be free from Type III leakage for a period of two and one half (2-1/2) years after delivery of the aerial device to the purchaser.

WARRANTY - TELESCOPIC WATERWAY ASSEMBLY

The manufacturer of the aerial device shall guarantee to the purchaser to repair or replace any defective or prematurely failed Telescopic Waterway Assembly, resulting from structural defects or failures, for a period of ten (10) years after delivery of the aerial device to the purchaser.

00-95-0550

OEM Provided & Installed Hydraulic Generator on Apparatus

00-95-1E50

MAXIMUM OVERALL LENGTH REQUIREMENT

The apparatus specified shall be constructed with no restrictions to the maximum overall length.

00-95-2E50

MAXIMUM OVERALL HEIGHT REQUIREMENT

The apparatus specified shall be constructed with no restrictions to the maximum overall height.

00-95-5E50

MAXIMUM WHEEL BASE REQUIREMENT

The apparatus specified shall be constructed with no restrictions to the maximum wheel base.

85-00-0020

75 FOOT REAR MOUNT AERIAL LADDER SPECIFICATIONS

85-00-0300

GENERAL INFORMATION

10247-0002

Toyne Inc.

The aerial ladder assembly shall be a three (3) section telescoping steel ladder, with a pre-piped waterway, steel turntable, torque box and outriggers.

85-02-0010

INTENT OF AERIAL SPECIFICATIONS

The intent of these specifications is to describe a telescoping elevating ladder of the true ladder type. It shall consist of three (3) steel ladder sections, a steel turntable, a tube torque box and two outriggers. The rated vertical height of the unit shall be **75'** and the rated horizontal reach shall be **66'**.

It is the intent of the purchaser that the device must meet all the requirements of the National Fire Protection Association's (NFPA) 1901, Standard for Automotive Fire Apparatus. It is also the intent of the purchaser to secure a fire service proven piece of apparatus that shall be manufactured in the U.S.A.

It is not the intent of the purchaser to deviate from this requirement; therefore, ladders attached to booms, whether solid or lattice, or articulating arms shall not be considered as meeting these specifications or the intent of these specifications.

DESIGN STANDARDS

The design criteria of the unit shall be to create a structure and system that emphasizes safety, product reliability, and ease of operation. These criteria are:

1. All structural load supporting elements of the aerial ladder that are made of a ductile material, shall have a design stress of not more than 50 % of the minimum yield strength of the material based on the combination of the rated capacity and the dead load. This 2:1 structural safety factor meets the American National Standards Institute (ANSI) and National Fire Protection Association (NFPA) 1901, Standard for Automotive Fire Apparatus, standard.
2. The aerial device shall be capable of sustaining a static load one and one-half times it's rated tip load capacity (live load), in every position in which the aerial device can be placed when the vehicle is on a firm and level surface.
3. The aerial device shall be capable of sustaining a static load one and one-third times it's rated capacity (live load) in every position in which the aerial devices can be placed when the vehicle is on a slope of five degrees downward in the direction most likely to cause overturning.
4. The hydraulic system shall be designed so that if a failure of any component or assembly

10247-0002

05/15/18

Toyne Inc.

within the system occurs, a single point failure of the entire system will not occur.

5. The aerial shall be capable of operating with a rated tip load of either of the two of the following conditions:

- A. Conditions of high wind of up to 38 mph.
- B. Conditions of icing, up to a coating of .25" over the entire aerial structure.

The manufacture shall state what wind and ice conditions their aerial device is capable of operating without reducing the rated tip load. **NO EXCEPTION!**

All of the design criteria must be supported by the following test data:

1. Strain gauge testing of the complete aerial device certified by a **Registered Professional Engineer**.
2. Analysis of deflection data taken while the aerial device was under test load.
3. Hydraulic component operating and burst strength testing.

MATERIAL STANDARD

All structural materials used in the aerial shall be certified by the mill of the manufactured material. Materials that are not certified shall not be acceptable.

85-02-0210

AERIAL LADDER MOUNTING

The elevating aerial ladder turntable shall be rear mounted thus providing the following vehicle benefits:

1. Improved mobility vs. mid-ship mounted units, due to shorter overall travel length and wheelbase.
2. Increased compartmentation, hose load and water capacity in body, resulting from ladder being raised to clear the cab.
3. Shorter vehicle wheelbase.
4. Shorter overall length of vehicle.

85-02-0300

10247-0002

Toyne Inc.

HEIGHT AND REACH

The height of the unit shall be a minimum of **75'** as measured by (NFPA) 1901, Standard for Automotive Fire Apparatus, requirements, which requires the rated vertical height of an aerial ladder shall be measured in a vertical plane with the ladder at maximum elevation and extension from the outermost rung of the outermost fly section to the ground. The bidder will state the height of the unit as measured by (NFPA) 1901, Standard for Automotive Fire Apparatus, standards.

The horizontal reach of the unit shall be a minimum of **66'** as measured by (NFPA) 1901, Standard for Automotive Fire Apparatus, requirements, which states, "The rated horizontal reach of an aerial ladder shall be measured in a horizontal plane from the centerline of the turntable rotation to the outermost rung on the outermost fly section with the aerial ladder extended to its maximum horizontal reach." The bidder shall state the reach of the unit as measured by (NFPA) 1901, Standard for Automotive Fire Apparatus, standards.

85-02-0450

WELDMENT FIXTURES

To ensure exact tolerances between parts and part interchangeability, all weldments shall be manufactured in fixtures. To further insure weld integrity in all weldments, all ladder fixtures must be able to position the weldments in the number 1 flat welding position resulting in maximum weld penetration in the welded material for both the tack and final weld process of the ladder.

85-02-0500

AERIAL APPARATUS CERTIFICATIONS (TYPE 1)

The aerial device shall be tested in compliance with the National Fire Protection Association's (NFPA) 1901, Standard for Automotive Fire Apparatus.

The following tests shall be conducted by personnel holding a Level II certification to detect defects and improperly secured components:

1. Magnetic particle inspection shall be conducted on all ferrous welds to assure the integrity of the weldments and also detect any flaws or weaknesses. These tests shall be performed prior to paint or assembly.
2. Ultrasonic inspection shall be used to detect any flaws in pins, bolts and other critical mounting components. The bolts shall be tested after they have been torqued to ensure the bolt was not damaged.

Toyne Inc.

3. All extension/retraction cables shall be tested and certified by the cable vendor.
4. Functional tests, load tests, stability tests and visual structural examination shall be performed. These tests will determine any unusual deflection, vibration, or instability characteristic of the unit.
5. Hydraulic oil shall be sample tested prior to delivery.
6. A waterway system flow/pressure test shall be performed.

Upon completion of the preceding inspections, the independent testing company shall issue a Certificate of Inspection indicating that all specified standards have been satisfied. The Type I certification shall be provided by **Underwriters Laboratories, LLC (UL, LLC)**. Aerial manufacturers not utilizing third party, independent testing companies shall not be acceptable.

TESTS

The following test shall be conducted to the aerial device prior to delivery; all listed tests shall be witnessed and certified by Underwriters Laboratories, LLC (UL, LLC) to ensure the device meets all current requirements of (NFPA) 1901, Standard for Automotive Fire Apparatus.

1. 1-1/2:1 DYNAMIC STABILITY AND LIFT TEST - A test of the apparatus shall be performed that the ladder sections are so designed and powered to support a load representing 150% of the manufacturer's rated tip load capacity at maximum horizontal reach on level ground. Since this is a dynamic test, the load must be raised, lowered and rotated without evidence of instability.

2. 1-1/3:1 DYNAMIC STABILITY AND LIFT TEST - A test of the apparatus shall be performed that the tip and ladder sections are so designed and powered to support a load representing 133% of the manufacturer's rated tip load capacity at maximum horizontal reach on a five (5) degree slope. Since this is a dynamic test, the load must be raised, lowered and rotated without evidence of instability.

3. TIME TEST - A test of the apparatus shall be performed to raise the ladder from a bedded position extended to full height and rotated through a 90 degree turn smoothly and without undue vibration in not over 120 seconds.

4. WATER TOWER TEST #1 - A test of the apparatus shall be performed to test its ability to discharge 1000 gallons per minute parallel to the ladder with the unit at full extension and zero degree elevation. The unit shall be capable of performing this test while loaded to its

Toyne Inc.

rated tip load capacity.

5. WATER TOWER TEST #2 - A test of the apparatus shall be performed to test the ability to discharge 1000 gallons per minute, 90 degrees to the side of the ladder with the ladder at full extension, zero degree elevation. The unit shall be capable of performing this test while loaded to its rated tip load capacity.

Bidders must state their ability to comply with all of the above tests. Failure to do so shall be grounds for rejection of their bid.

85-04-0210

AERIAL DEVICE PAINTING

Prior to any painting, all weldments such as the outrigger beams, torque box, turntable, and aerial ladder sections shall be shot blasted, cleaned and inspected to insure the removal of any surface imperfections and to insure superior paint adhesion to the metal.

The entire painting system shall utilize a single manufacturer's paint for compatibility between primers and finished coats. The paint shall be PPG Industries Delta® brand, applied throughout a multi-step process. All painting shall be done in atmosphere controlled spray booths. The weldments will then be primed with a Ditzler PPG zinc corrosive inhibitor and a Ditzler (PPG) Epoxy Primer. All seams between adjoining pieces that are not continuously welded shall be caulked to inhibit corrosion.

Before assembly, in preparation for final painting, the aerial unit shall be thoroughly cleaned, conforming to good painting practices.

85-04-0240

AERIAL DEVICE PAINT

bolt on front tip to be painted red

85-04-0250

TORQUE BOX PAINT

85-04-0390

SIGN PANEL PAINT

85-04-0410

The egress shall be left in a "Natural" Stainless Steel finish.

85-04-0700

The finished paint color shall be PPG 925849 (2185) white enamel, allowing easy touch-up

10247-0002

05/15/18

Toyne Inc.

after extended use.

85-04-0700

The finished paint color shall be PPG 925849 (2185) white enamel, allowing easy touch-up after extended use.

85-04-0720

The finished paint color shall be PPG 9000 black enamel, allowing easy touch-up after extended use.

85-04-0730

The finished paint color shall be PPG 33723 silver enamel, allowing easy touch-up after extended use.

85-10-0050

HYDRAULIC SYSTEM

The hydraulic system shall provide power in as efficient a manner as possible. The system shall use a piston type load sensing pump and shall be capable of operating under any rated load condition and aerial position at normal engine idle (slow idle) or governor controlled fast idle. The piston pump shall be capable of generating sufficient flows to allow multiple function operation without significant loss of speed.

The system shall not be dependent upon an auxiliary cooler to control system temperature.

85-10-0110

POWER TAKE OFF (PTO)

The apparatus shall be equipped with a "Hot-Shift" power take-off (PTO) driven by the chassis transmission. The PTO shall be actuated by an electric switch located inside the cab. An indicator light shall be located in the cab to show when the PTO is engaged.

The PTO shall only engage with the parking brake applied and the transmission in neutral or drive if the fire pump (if equipped) is engaged. The PTO shall be a heavy-duty pressure lubricated and cooled unit for extended operations.

A master "Ladder Power" switch shall be provided for engagement of all ladder hydraulic functions and 12-volt power. The emergency pump circuit shall be controlled separately.

85-10-0130

OUTRIGGER/AERIAL INTERLOCK

The aerial hydraulic system shall include an interlock feature that will prevent the accidental operation of the outriggers during aerial operation. This interlock shall also prevent

10247-0002

05/15/18

Toyne Inc.

accidental operation of the aerial device prior to the outriggers being properly deployed.

In the event of electrical failure, the operator shall be able to override the hydraulic system to operate the aerial device or outriggers for continuous, uninterrupted operation. A 5,000 psi hydraulic oil pressure gauge shall be provided and installed at the override location to monitor the overall pressure of the hydraulic system.

85-10-0150

HYDRAULIC OIL RESERVOIR

A 34 gallon hydraulic oil reservoir shall be provided to supply the needs of the hydraulic system. The tank shall be constructed from 7 gauge aluminum, which shall be welded at all interior and exterior seams.

Gated suction and drain lines shall be provided between the oil reservoir and the primary hydraulic pump. The tank fill shall be provided with a strainer screen, vent cap and magnetic drain plug. There shall be a sight level gauge for checking fluid levels.

The tank shall be cleaned and free from all contaminants before adding any fluid.

85-10-0290

HYDRAULIC SYSTEM FILTRATION

Outgoing and return line filtration shall be provided. The pressure and return filters shall be easily accessible for maintenance.

85-10-0300

Outgoing filtration shall be in the form of a pressure line filter installed between the hydraulic pump and entrance to any system components. The filter shall have an absolute rating of ten (10) microns. The pressure filter shall have a bypass circuit protected by a 50-psi check valve, which shall be installed around the pressure filter. The pressure line filter shall be required even if a suction line filter is provided in the reservoir due to the suction line filter's inability to trap contaminants entering the system.

A filter condition indicator shall be provided.

85-10-0310

The return line flow shall be filtered by means of a return line filter. This filter shall have an absolute rating of ten (10) microns.

85-10-0400

EMERGENCY HYDRAULIC PUMP SYSTEM

In the event of failure of the main hydraulic pump or vehicle engine, the unit shall be

10247-0002

Toyne Inc.

equipped with an emergency hydraulic pump.

The pump shall be plumbed into the hydraulic system and shall be electrically driven from the chassis batteries. The emergency pump shall be capable of limited functions of the ladder and outriggers to stow the unit. The pump shall be controlled from the right and left outrigger control stations with spring loaded momentary contact switches.

The emergency pump shall have a separate hydraulic oil supply line, attached directly to the hydraulic oil reservoir. A shutoff valve shall be provided and a check valve shall be incorporated on the pressure side of the pump.

85-10-0500

OUTRIGGER SYSTEM HYDRAULIC CONTROL VALVES

A directional control valve that is designed for parallel hydraulic circuit operations shall control the outrigger cylinder system. This valve shall be modular in design so that individual sections can be replaced in the field, rather than complete valve assemblies, thus reducing maintenance costs. Each valve shall be equipped with a heavy-duty electric solenoid for electric control of the outrigger from the remote operator's station.

85-10-0550

LIFT, EXTENSION AND ROTATION HYDRAULIC CONTROL VALVE

A three-function hydraulic proportional valve bank shall control ladder functions. The valve shall be located at the turntable with direct linkage controls.

85-10-0600

HYDRAULIC HOSE, TUBING AND FITTINGS

All hydraulic steel tubing, hydraulic rubber covered wire-braided hoses, and hydraulic fittings/adapters shall have a minimum burst pressure rating of four times the operating pressure. Hoses and tubing shall be properly sized to minimize heat buildup during extended periods of operation. Hoses and tubing shall be properly sized to minimize flow restrictions.

All hydraulic hose shall have a tube and cover constructed of Nitrile elastomers and shall have braided/spiral wire reinforcement capable of maintaining a 4:1 safety factor in all areas of the hydraulic system. The hose shall meet the appropriate SAE performance specifications: 100 R2 or 100R12.

85-10-0700

The aerial hydraulic pump shall be drive shaft driven directly from the chassis provided PTO.

10247-0002

Toyne Inc.

The pump shall be "Thru Drive" in design to allow the hydraulic generator pump to be directly attached and powered by a single PTO output.

85-12-0110

ELEVATION SYSTEM

Two (2) double-acting lift cylinders shall provide smooth, precise elevation from 7 degrees below horizontal to 80 degrees above horizontal. Units that do not operate below minus 6 degrees shall not be acceptable.

The lift cylinders shall have a 6" internal diameter, 3-1/2" diameter cylinder rod and a 36-1/8" stroke. Integral cylinder holding valves shall be provided to prevent the unit from lowering should the charge lines be severed at any point within the hydraulic system. Units that do not use holding valves on the cylinders shall not be acceptable. A hydraulic holding valve shall be provided in the elevation circuit to retain the aerial ladder in its bed when the vehicle is in motion.

The elevation cylinders shall be provided with both rod and piston "hydraulic cushions". The cushions shall serve to decelerate the cylinder near the end of its stroke resulting in a smooth stop at full cylinder stroke.

85-12-0200

LADDER INTERLOCK SYSTEM

A limit switch at the aerial travel support shall be provided to prevent operation of the outriggers once the aerial device has been elevated from the nested position.

85-12-0210

EXTENSION/RETRACTION SYSTEM

A full hydraulic powered extension and retraction system of the ladder shall be provided through dual hydraulic cylinders and cables, each capable of operating the ladder in the event of failure of one of the systems.

The extension/retraction cylinders shall be equipped with integral (on the cylinder) holding valves to prevent the unit from falling should the charge lines be severed any point within the hydraulic system.

The extension cylinders shall be provided with both rod and piston "hydraulic cushions". The cushions shall serve to decelerate the cylinder near the end of its stroke resulting in a smooth stop at full cylinder stroke.

Toyne Inc.

Cylinders in excess of 25 feet with the rod extended, or that require the attachment of the rod to the mid section, shall not be desirable for two (2) reasons that are not consistent with the level of quality desired by the purchaser:

1. Rod attachment to the mid section requires that the lower rung rail cannot be sealed from the atmosphere and therefore long-term corrosion cannot be adequately controlled.
2. The cylinder shall be subjected to the buckling forces caused by normal ladder deflection.

Cables attached to the base and mid ladder sections shall be routed over sheave wheels on the base section and cylinder sheave mount. This cabling arrangement shall act as a stroke multiplier to provide full-power ladder extension and retraction.

Dual extension/retraction cables shall have a minimum safety factor of 5:1 and shall be of the following diameters:

Mid Section: 1/2"

Fly Section: 5/16"

85-12-0400

EXTENSION INDICATORS

Reflective numerals shall be affixed to the inside of the handrail of the base section opposite the turntable control console. The numerals shall be at appropriate intervals indicating total aerial extension in 10-foot increments. A band on the first fly section shall align with these marks at the appropriate extension distance. An additional stripe shall be provided between the numbered stripes to indicate each 5 feet of aerial extension.

The extension indicator color shall provide a high contrast with the color of the ladder section to which it is applied.

This shall make the length of aerial extension easily readable by the operator by merely glancing at the indicators.

85-12-0410

LADDER SLIDE MECHANISM

UHMW slide pads shall be provided on each ladder section for load transfer between sections. The pads shall utilize low coefficient of friction materials to reduce the resistance between the pads and ladder sections.

85-12-0450

AIR/ELECTRIC LADDER TRACK

10247-0002

Toyne Inc.

All air and electric line routing from the turntable to the tip of the aerial device shall be accomplished using a flexible conduit system. Routing shall be such that cables shall be fully enclosed except at points of transition between sections.

The conduit shall run along the handrail uprights, between the ladder sections, so the conduit does not decrease the interior width of the ladder.

85-12-0470

The extension markers shall be provided in red reflective material.

85-14-0130

ROTATION SYSTEM

An external tooth monorace bearing shall be provided for 360 degree continuous rotation in either direction. To ensure proper bearing installation and long service life, surfaces of both the open base bearing plate and the turntable bearing plate shall be milled. Units that do not have milled bearing surfaces shall not be acceptable.

The bearing shall be bolted to the turntable and bolted to the open base support plate, using 7/8" diameter Grade 8 bolts. A planetary drive, powered by a hydraulic motor, shall provide precision rotation control throughout 360 degrees of rotation. A spring-applied, hydraulically-released disc type brake shall be furnished to provide positive braking of the turntable assembly against reactionary forces such as water flow and gravity.

The turntable rotation bearing shall be easily accessible for lubrication and retorquing of bolts from the turntable side, for ease of access.

Access to the turntable bearing bolts which requires the removal of the ground ladders and/or the ground ladder slide assemblies, during bolt retorquing process, shall not be acceptable.

85-14-0170

ROTATION LIMITING SYSTEM

An aerial ladder rotation limiting system shall be provided to notify and prevent the operator from rotating the aerial ladder into a restricted position due to a "short-set" outrigger configuration. The system shall enable the operator to place the aerial ladder in a 180 degree rotation to the opposite side of the apparatus than that of the "short-set" outriggers only.

Indicator lights shall be provided on the turntable control console to indicate outrigger not deployed status.

Toyne Inc.

In order to rotate the aerial ladder with a outrigger "short-set", the aerial interlock override control momentary switch located in the turntable control console shall require to be continuously activated while rotation of the aerial is in process. The system shall be capable of rotating the ladder slightly past the centerline of the apparatus on the "short-set" side to enable bedding of the ladder within the travel support structure without system cutout.

The rotation interlock system shall allow for normal operation on the side of the apparatus where the stabilizers are sufficiently extended for full tip load rating.

85-26-0210

TORQUE BOX

A torsion box sub-frame shall be installed over the chassis frame rails. The torque box assembly shall be capable of withstanding torsion and bending loads.

The torque box shall be bolted to the chassis frame with .75" SAE grade 8 bolts and Huck fasteners. The torque box shall be constructed of 0.375" steel bottom plate and a stiffened top plate.

The torque box shall be designed to enclose the ground ladders.

85-28-0200

OUTRIGGER DEPLOYMENT WARNING ALARM

An audible outrigger deployment-warning device shall be provided to warn personnel in the vicinity of the apparatus that the outriggers are in motion.

Whenever an outrigger control handle is utilized, the device shall produce a pulsing tone, separate and distinctive from that of other audible warning systems provided on the apparatus. When the outrigger control handle is released to its neutral position, the signal shall cease.

The warning device shall automatically enable the dB level to be raised or lowered by measurements of the ambient noise level.

85-28-0210

Retro-reflective material shall be provided and installed on both sides of the horizontal and vertical beams of the outriggers.

85-30-0030

TURNTABLE/TURNTABLE DECK

The turntable shall be a fabricated steel weldment designed for the rotation and elevation of

10247-0002

Toyne Inc.

the ladder sections. It shall consist of the following:

A steel bearing plate and matching top plate shall be machined to insure proper fit to the rotation bearing. Manufactures that do not mill both bearing surfaces shall not be acceptable.

Embossed aluminum diamond plate deck shall cover the entire turntable frame, providing a walking surface.

An embossed aluminum diamond plate access step shall be mounted at heel of the ladder.

All handrails shall be a minimum of 42" high. For ease of grip, the handrail shall be manufactured from 1-1/4" O.D. knurled stainless steel material.

Turntables with the drive motor or breathing air bottles mounted in any walking areas (front or rear) of the turntable shall not be acceptable.

85-32-0050

The right side of the turntable deck shall be designed to allow access to the side hose bed.

85-32-0170

TURNTABLE ACCESS SAFETY CHAINS

The one (1) turntable handrail opening shall be equipped with safety chains at the rear of the turntable.

85-32-0300

CRADLE ALIGNMENT INDICATOR ARROWS

Aluminum arrows with red Scotch-Lite coating shall be provided on the turntable surface, and on the apparatus body to indicate the alignment of the aerial ladder with the ladder travel cradle. The indicators shall be suitably illuminated for night time operation.

Mechanical fasteners shall be used for installation.

85-34-0010

HYDRAULIC, ELECTRIC AND WATER SWIVEL

Hydraulic power to the turntable hydraulic circuits shall be provided through a three-port, high pressure hydraulic swivel permitting 360 degrees continuous rotation of the turntable.

Toyne Inc.

Water shall be transferred to the aerial waterway by means of a 4" internal diameter water swivel, permitting 360 degree continuous rotation.

Electric power to the turntable electric circuits shall be comprised of a minimum of twenty two (22) ring collector assembly, permitting 360 degree continuous rotation of the turntable.

85-36-0210

HEAVY DUTY LADDER TRAVEL SUPPORT

A heavy duty ladder rest shall be provided for support of the ladder in the travel position. The ladder rest shall be attached to the chassis frame rails immediately rearward of the cab. The travel support shall be fabricated from heavy duty steel tubing and shall be designed to be easily removable to allow for ease of maintenance and repair if necessary.

The base section of the ladder shall contain stainless steel scuff plates where the ladder comes into contact with the ladder support. The travel rest shall be painted to match the torque box.

An indicator light shall be provided on the turntable to indicate when the ladder is aligned with the travel support and may be lowered into it.

85-38-0010

AERIAL LADDER SECTION CONSTRUCTION

The aerial ladder shall be comprised of three (3) sections. The ladder section design objective shall complement the support of heavy or uneven aerial loads at low angles of elevation, or at full extension. Each ladder section shall be fabricated in fixtures assuring uniformity, replaceability, or changeability, and shall be welded in accordance with American Welding Standards (AWS) criteria by certified welders.

The ladder sections shall be constructed of welded high-strength steel throughout. Each section shall be trussed diagonally, vertically, and horizontally, using steel rectangular tubing, reinforced at critical points for extra rigidity, thus giving a high strength-to-weight ratio. Each section shall be equipped with 1-1/4" diameter rungs, placed at no greater than 14-inch centers for ease of climbing.

To assure the level of quality desired, each ladder section shall include the following:

1. Base Section - All rails, including the lower rail, shall be sealed from the atmosphere. The base ladder section shall include a triangulated lifting configuration. This arrangement shall consist of front and rear cross tubes, forward triangle tube, rear triangle tube, lift cylinder outboard support tube and steel plating welded into place where the lifting cylinders attach to the aerial ladder base section.

10247-0002

05/15/18

Toyne Inc.

2. Mid Section and Fly Section - All rails, including the lower rung rail, shall be sealed as described for the base section.

All ladder rungs shall be welded to each rung rail section in two (2) places. K-bracing shall be provided between the rungs and the ladder rung rails to provide the ability to discharge water at 90 degrees to the side of the ladder.

All rungs shall be round and covered with deeply serrated, replaceable, heavy duty rubber sheaths, which shall be both glued and clamped securely to the rungs with metal clips. Due to high maintenance cost and difficulty in replacement of anti-slip rung surface and the inability to provide a safe surface during icing conditions, ladder designs that do not utilize rubber rung covers shall not be acceptable.

85-38-0200

LADDER SECTION DIMENSIONS

All bidders shall state in the space provided below their dimensions on the unit proposed. Dimensions proposed must equal or exceed these specified.

Handrail	Height	Width
Base Section	22.125	33.75"
Mid Section	19.625"	30.50"
Fly Section	17.50"	26.00"

85-38-0410

LADDER EGRESS

A removable bolt on stainless steel egress shall be installed on the tip of the fly section. Only certified structural fasteners shall be utilized to attach the egress to the tip of the fly section. Additionally, the fasteners shall be stainless steel. This design shall allow for easy replacement should the egress become damaged during rescue operations. This shall prevent the department from experiencing serious downtime, as is common with welded on egresses. For this reason, a design that allows the egress to be welded to the fly section shall not be acceptable.

The egress shall have knurled handrails with an extended radius design at the tip to eliminate corner joints, and increase strength. The straight design of the egress will allow the aerial waterway monitor/nozzle to be placed up to 30 degrees above horizontal centerline for additional range of water stream operation.

10247-0002

05/15/18

Toyne Inc.

The rungs on the egress shall be held to the same design load criteria as the rungs of the aerial ladder sections. This mean that each egress rung shall be able to support a design load of 500 lbs. minimum, distributed across the rung, as specified in NFPA 1901. This shall be in excess of that required by the aforementioned standard.

85-40-0410

FLY SECTION FOLDING STEPS

Two (2) spring-loaded aluminum folding steps with non-slip aluminum grating inserts shall be installed in the fly section of the ladder to provide footing for an operators stationed at the tip of the fly section. Springs shall hold the steps in place during use and secure the steps in the stowed position when not in use. Each step shall have a surface area of 72 square inches and a minimum design load of 500 lbs.

85-44-0010

OUTRIGGERS

Two (2) "H" style, "out and down" outriggers shall be located behind the rear wheels to provide vehicle stability during aerial tower operation.

The extension of the horizontal outrigger beams shall provide a 14' outrigger stance. Five (5) slide pads shall be provided for each outrigger beam assembly to provide smooth operation and to extend the life of the outrigger.

For ease of service, the vertical jack cylinders shall be designed so they can be removed from the top. Designs that require the removal of the horizontal beams or dropping the cylinder out the bottom shall not be acceptable.

85-48-0070

EXTENSION CYLINDERS

Each extension cylinder shall have a 3.00" internal bore with a minimum 2.00" chrome plated cylinder rod.

The extension cylinders shall be fully enclosed within the outrigger beam, preventing them from being nicked or scored during operations on the fire ground.

85-50-0010

JACK CYLINDERS

Each jack cylinder shall have a 5.00" internal bore with a 3.50" chrome plated cylinder rod. The jack cylinders shall be equipped with integral (on the cylinder) holding valves, which

10247-0002

Toyne Inc.

shall hold the jack cylinder in either the stowed position or the deployed position should a hydraulic line be severed at any point within the hydraulic system.

To minimize side loading and subsequent seal failure of the vertical jack cylinder, a 1.62" wide load bearing UHMW wear band shall encircle the jack cylinder barrel, providing load distribution over a 360 degree plane. Designs which could allow load concentration on one side of the vertical jack cylinder shall not be acceptable.

In order to provide faster setup time for the aerial on the fire ground, and to eliminate the possibility of damage to the housing should the outriggers be retracted with the jack pins left in, designs that require the use of jack pins shall not be acceptable. .

For ease of maintenance, the outer jack tube shall be designed so that the cylinder can be removed from the top. Designs that require the outrigger beams to be removed or the jack cylinder positioned over a pit for jack cylinder removal, shall not be acceptable.

85-50-0100

OUTRIGGER BEAM PAINT

85-52-0010

OUTRIGGER PADS

A permanently attached self-centering floating type 1/2" thick, 154 sq. inch steel pad shall be provided on each outrigger. The pad shall swivel and require no adjustment during outrigger set-up.

The outrigger pad shall be attached without the use of a bearing type swivel due to maintenance required on this design. Outrigger pads that pivot in only one plane shall not be acceptable due to their inability to distribute loading over the total pad surface on uneven terrain.

85-52-0020

AUXILIARY OUTRIGGER PADS

Two (2) auxiliary outrigger ground pads shall be provided for additional load distribution. Each ground pad shall be fabricated of 6061-T6 high strength aluminum alloy and shall measure 3/8" x 24" x 24". Each ground pad shall be equipped with a handle for easy use.

85-54-0010

AERIAL/OUTRIGGER INTERLOCK SYSTEM

An interlock system shall be provided between the outriggers and aerial device that prevents the operation of the aerial until the operator places all jacks in the load-supporting

10247-0002

Toyne Inc.

configuration. All jacks shall be equipped with a ground force sensitive switch that closes only when the jack is firmly in contact with the ground.

Until all the switches close, electrical and hydraulic power shall not be transmitted to the turntable, hence preventing aerial operation. Green indicator lights shall be provided on the outrigger control panel to indicate that the outrigger foot is in firm contact with the ground and in a load supporting position.

86-00-0020

AERIAL WATER SYSTEM

The aerial waterway system shall be capable of being supplied by both the pump and an external water source with the inlet on the rear of the apparatus.

All piping from the pump or the inlet at the rear of the apparatus to the riser pipe below the turntable swivel shall be 4" Schedule 40 aluminum 6061 T6 pipe. Piping at the rear of the torque box shall terminate with a Victaulic groove for installation of OEM provided and installed rear inlet piping/termination fittings. Piping at the front of the torque box shall also terminate with a Victaulic groove for connection to the OEM provided and installed fire pump and plumbing. A 4" tee shall join the pump discharge line and the rear inlet line.

A 4" water swivel shall be located in the riser pipe from the tee permitting 360-degree continuous rotation of the ladder.

A 4" heel pin swivel connection between the ladder waterway and the turntable swivel permitting water tower operations thru full aerial elevation range shall be provided.

A 2-1/2" adjustable relief valve shall be located beneath the turntable to protect the water system from excessive pressures.

86-12-0010

WATER SYSTEM FRICTION LOSS

The aerial ladder and its waterway system shall be capable of flowing 1000 GPM at 100 psi nozzle pressure at full elevation and extension. The friction loss (total system loss less head loss) shall not exceed 100 psi at 1000 GPM flow with the ladder at full horizontal extension. The pressure reading for friction loss measurement shall be taken at the base of the monitor and at a point below the waterway swivel.

86-12-0100

TELESCOPIC WATERWAY

An anodized aluminum telescopic waterway shall be mounted beneath the center of the aerial

10247-0002

Toyne Inc.

ladder. The waterway shall have a 4" base section tube, 3-1/2" mid section tube and a 3" fly section tube.

86-14-0030

AERIAL WATERWAY FLOWMETER

The apparatus shall be equipped with a Fire Research Insight digital flowmeter. The flowmeter case shall be waterproof and shall be manufactured of anodized machined aluminum. It shall have an LED display with super bright digits more than 1/2" high.

The flow meter shall be checked and calibrated prior to delivery of the apparatus.

Display shall be located at the turntable control console.

86-16-0210

MOVABLE MONITOR FEATURE

The aerial ladder waterway monitor shall be capable of being positioned at either the fly section for water tower operation or at the next lower ladder section for rescue. The aerial ladder shall be capable of full extension and operation when the waterway is connected to either section of the ladder.

The waterway and monitor shall have a positive lever type latching system to secure them either to the tip of the fly section or next lower section of the aerial ladder. A latching system requiring a pin to be removed from one location and repositioned into another location shall not be acceptable due to the possibility of dropping the latching pin.

The monitor shall be remotely operable from either position and shall transfer the electrical power and controls automatically. Due to problems associated with aligning electrical connectors used to transfer power between rescue and water tower positions, the power transfer shall be achieved by a cable carrier system.

86-16-0510

AERIAL WATER SYSTEM

A minimum 4" water swivel shall connect from the aerial waterway supply piping to the telescopic aerial waterway. The water swivel shall permit full operation at any elevation of the aerial device. The aerial waterway pipes shall be designed to reduce friction loss in the waterway.

All aerial waterway piping shall be completely removable for service or replacement. Aerial designs in which the waterway is welded or utilized for structural integrity of the aerial shall not be acceptable.

10247-0002

Toyne Inc.

86-20-0010

ELECTRICALLY CONTROLLED MONITOR

An Akron Brass, model 3480 StreamMaster II, 2000 gpm electric monitor, constructed of lightweight Pyrolite, shall be installed on the outer end of the telescoping aerial waterway. The monitor relay box shall be located on at the tip of the aerial device, adjacent to the monitor, and will be easily accessible for service.

The monitor and nozzle functions shall be controlled from the tip of the fly section through hard wired connections and wirelessly from each of the aerial control station(s) specified. The monitor and nozzle controls at the tip and optional control stations shall consist of three (3) individual spring loaded, self-centering, and weather resistant toggle switches.

The monitor shall be capable of a vertical sweep of 165 degrees, and a horizontal sweep of 180 degrees (90 degrees to each side of the aerial center line).

NOTE: Monitor operation above 0 degrees (horizontal center line of the aerial ladder) reduces payload capacity by 250 lbs.

86-22-0130

An Akron Brass, model 5177, Akromatic 1250 electric combination fog and straight stream nozzle with automatic flow mechanism that provides a flow range of up to 1250 gpm at 80 psi shall be provided. The nozzle shall be constructed of durable, lightweight Pyrolite and shall have electric pattern selection from straight stream to wide fog controlled by a 12V motor and linear ball screw, a manual override pattern control knob, and a built-in stream shaper.

86-50-0010

LADDER CAPACITIES

The following ladder tip load capacities shall be established with the truck level, the outriggers fully extended and lowered to relieve the chassis weight from the axles. Capacities are based upon full extension and 360 degree rotation.

86-50-0500

AERIAL CRITERIA AND STANDARDS

The following aerial ladder capabilities shall be established in the unsupported configuration with the truck level, the outriggers fully extended and lowered to relieve the chassis weight from the suspension. The capacities shall be based upon 360 degree continuous rotation and up to full extension. The ratings shall be based on average weight of personnel on ladder at 250 lbs. each.

10247-0002

Toyne Inc.

The ladder shall be designed to permit 500 pound tip load, up to full ladder extension from -7 to 78 degree elevation. In addition to the 500 pound personnel allowance, 100 pound allowance shall be included for equipment mounted on the fly section of the ladder .

Elevation	Tip or Evenly Distributed Load
-7 to 45 degrees	500 pounds @ tip or 1000 pounds evenly distributed
46 to 78 degrees	500 pounds @ tip or 2000 pounds evenly distributed

86-50-0510

WATER TOWER OPERATION CAPABILITIES:

The ladder and water system shall be designed to permit 1500 GPM flow with water stream parallel to ladder or 90 degrees to either side of the ladder.

Ladder Elevation	Stream Elevation	Tip Load
-7 to 78 degrees	From Parallel To -135 Degrees	500 Pounds
-7 to 78 Degrees	From 30 Degrees to -135 Degrees	250 Pounds

86-50-1000

OPERATIONS ON GRADES

The aerial unit shall be capable of leveling on a slope of 8 degrees. Operation beyond this limit shall be at operator's discretion. Devices that cannot provide this leveling capability are not acceptable.

86-52-0010

OUTRIGGER CONTROLS

Two (2) illuminated outrigger control stations shall be provided, one (1) on each side of the rear of the vehicle. For safety, ease of deployment and operational speed, the outrigger controls shall be of the hydraulic proportional type with manual overrides immediately accessible.

The outrigger controls shall be enclosed in a recessed compartment to protect each control from damage or accidental movement. The controls shall be located such that the operator can see the outrigger he is operating. Body designs that block the view of the outriggers from the control station shall not be acceptable.

Each outrigger control function shall be operated independently, so that the vehicle may be set up in restricted areas or on uneven terrain.

Each outrigger control station shall incorporate the following:

Toyne Inc.

- Outrigger beam and jack actuator controller
- Outrigger/Jack deployed indicator light
- Fast idle switch
- Emergency pump control switch
- Warning decals

86-54-0010

AERIAL CONTROL STATION

There shall be an aerial control station located at the turntable. All elevation, extension and rotation operational controls shall operate from this position. These controls shall be arranged to permit the operator to regulate the speed of these operations within the safe limits as determined by the manufacturer. Load instruction plates shall be located at the control station to show the recommended safe load of the ladder. The control devices shall be clearly marked and suitably lighted.

86-56-0010

TURN TABLE CONTROL STATION

The control station shall be located on the left side of the turntable, as the operator is facing the tip of the nested aerial ladder (Driver's side of the apparatus), in order to provide increased visibility of the ladder tip while operating the controls. The lower part of the console shall be angled away from the operator, to provide as much foot room as possible for the operator.

The pedestal shall be constructed from an aluminum framework with an aluminum diamond plate wrapper. Access to the electrical and hydraulic components mounted inside the console shall be provided by either hinged doors or removable access panels. A hinged cover shall be provided over the console to protect the panel and controls. The top of the console shall be angled to face the operator for ease of ladder operation.

The console and turntable working areas shall be illuminated for night operations, and shall have all controls and indicators clearly marked.

Controls and indicators provided shall include, but shall not be limited to;

Three (3) ladder function control levers.

A foot operated "**dead man switch**", which shall protect against accidental movement of the control handles.

Rung alignment indicator light for ladder climbing operations.

Toyne Inc.

Cradle alignment indicator light on console.

Engine high idle control switch.

Aerial Override Switch for Short Jack Situations.

Short Jack Indicator Lights.

Intercom controls in console lid.

Bubble type angle indicator on base section near console.

Illuminated load chart.

Tracking Light Switch.

Monitor/Nozzle Control Switches.

Monitor Stowed Indicator.

Flowminder Display (If Selected).

Hydraulic Oil Pressure Gauge Inside pedestal

Any additional switches and/or displays required by other options described elsewhere within these specifications, as available space permits.

86-56-0100

The control console lid shall be provided with a black Line X finish.

87-00-0010

AERIAL ELECTRICAL SYSTEM

12VDC electrical power for the aerial device shall be drawn from the chassis electrical system and routed through major segregated circuits and into an electric collector ring assembly. The circuits shall provide power for the aerial device controls, indicators, and interlocks; other circuits shall power auxiliary equipment such as lights, intercom, etc.

The electric collector ring assembly shall provide power for electrical ground, ladder control functions, 12 and 120 volt systems. The collector rings shall be enclosed in a sealed, weatherproof housing to prevent corrosion.

Toyne Inc.

All aerial device wiring shall be multi-conductor, copper 18 gauge (minimum), color-coded, with thermosetting cross-linked polyethylene insulation. All aerial device wiring shall be in pre-engineered harnesses with each circuit identified by number and color code. Harness connections shall be through locking, weatherproof, guided pin connectors.

87-00-0040

AIR HORN BUTTON

An air horn button shall be provided at the turntable control console.

87-00-0050

AERIAL PTO HOURMETER

An hourmeter shall be installed in the chassis cab as described elsewhere within these specifications. The hourmeter shall be wired to the PTO circuit to record hours of PTO operation for the aerial device. The hourmeter shall aid in scheduling preventative maintenance as outlined in the operator's manual.

87-00-0080

ENGINE HIGH IDLE ACTUATOR

The high idle actuator shall be used to raise the engine RPM to a preset level for proper aerial operation. The high idle switches shall be located in the chassis cab, at the stabilizer control station and the aerial control station.

For the safety of personnel and equipment, the high idle system shall not activate unless the interlock systems have been applied, the chassis spring brake is set, and the transmission is in neutral.

87-00-0100

OUTRIGGER LIGHTING AND REFLECTIVE STRIPING

Each outrigger shall be equipped with the following light and reflective striping package:

87-00-0150

There shall be an LED ground illumination light located at each outrigger or downrigger location to illuminate the footpad area.

87-00-0170

The lights shall be 4.00 inch (101.60 mm) diameter Trucklite LED model #44308C.

87-02-0010

COMMUNICATION SYSTEM

87-02-0030

10247-0002

Toyne Inc.

An Atkinson Dynamics two (2) station communication system shall be provided and installed between the ladder tip and the turntable operator's position. The communication speaker at the ladder tip shall require no operator attention to transmit or receive. The transmitting receiving volume controls shall be located at the turntable operator's position.

87-02-0310

Truck Lite 7" round LED red flashing lights shall be provided as warning lights when the outrigger beams are extended.

Each stabilizer beam shall be equipped with a total of two (2) lights, one (1) facing forward and one (1) facing rearward. The lights shall be mounted inboard of vertical jack tubes.

87-02-0400

Both the foot pad illumination lights and the flashing outrigger warning lights shall be activated by the aerial power switch.

87-06-0000

AERIAL SPOTLIGHTS

All 12VDC aerial spotlights lights shall be mounted below handrail height, so as not to increase the overall height of the vehicle.

87-06-0020

TRACKING LIGHTS

Two lights shall be mounted at the rear of the base ladder section handrails, one (1) each side. The lights shall be capable of swiveling 180 degrees.

87-06-0120

Two (2) Whelen Micro Pioneer series, 45 watt, 4,100 lumen, 12 VDC, LED work/scene lights shall be provided.

An "On/Off" switch and black handle shall be provided on each light along with three (3) interchangeable lenses. Lights shall be installed on a low profile stainless steel swivel pedestal mount.

87-06-1000

TIP LIGHT(S)

87-06-1160

Two (2) Whelen Micro Pioneer series, 45 watt, 4,100 lumen, 12 VDC, LED work/scene lights shall be mounted at the tip of the fly ladder section, one (1) each side.

An "On/Off" switch and black handle shall be provided on each light along with three (3)

10247-0002

05/15/18

Toyne Inc.

interchangeable lenses. Lights shall be installed on a low profile stainless steel swivel pedestal mount.

87-06-4020

The LED lighting shall be Blue.

87-06-5120

Light(s) shall include a die cast aluminum housing, powder coated black.

87-06-5120

Light(s) shall include a die cast aluminum housing, powder coated black.

87-06-5130

A chrome finish, polycarbonate rear cover shall be provided on the light(s).

87-06-5130

A chrome finish, polycarbonate rear cover shall be provided on the light(s).

87-08-0010

TURNTABLE WORK LIGHTS

Five (5) Arrow LED work lights shall be installed in the turntable step cover to illuminate the turntable area. The lights shall be automatically activated by the aerial master switch (day or night). The work lights shall be positioned so the light is directed toward the decking. The lights shall have integral chrome hoods to keep light from glaring upward into the operator's eyes.

87-08-0220

WALKWAY ILLUMINATION

The climbing area of the ladder shall be continuously illuminated utilizing a series of light emitting diodes (LED's). The LED's shall be located on both sides of each ladder section and shall be positioned near the ladder rails to maintain a clear walking area. A switch shall be provided on the turntable control console to activate the rung illumination lighting.

87-10-0030

AERIAL 110 VAC WIRING

The AC wiring up the ladder shall be Thermoplastic Elastomer (TPE) control cables and shall be highly flexible with very fine copper stranding. The cables shall have a center core strain relief for high tensile strength. The conductors shall be braided in bundles around the high tensile strength core. The outer jacket shall be gusset-filled, pressure-extruded, oil-resistant, bio-oil-resistant, PVC-free, halogen-free, and UV-resistant with low temperature

10247-0002

Toyne Inc.

flexibility. The cables shall have a minimum-bending radius of not greater than 5x the outer total diameter of the cable while moving.

One (1) 110 volt, 20 amp electrical circuit, utilizing a single 12 gauge, 3 conductor electrical cable, shall be provided to the tip of the ladder. The aerial device shall include an AC electrical connection point, for the OEM supplied and installed AC power source, below the rotation point of the aerial device. The wiring connection points shall be clearly identified at the rotation swivel for the OEM to connect AC power.

87-10-1100

OUTLETS AT THE AERIAL TIP

87-10-1260

One (1) NEMA L5-20R, 120-volt, duplex, 3-wire, twist lock receptacle shall be installed on the officer's side of the ladder tip. The receptacle shall have a 20-ampere rating and include a spring-loaded weather resistant cover if mounted in an exterior location. The receptacle shall be wired to the onboard generator.

87-12-0010

LADDER TIP 110V LIGHTING

87-12-0100

Two (2) 750-watt Fire Research Optimum Quartz lights shall be installed at the tip of the ladder, one (1) each side. The lights shall be wired to the aerial 110-volt circuit and shall be equipped with a switch on each lighthouse.

92-12-0060

EQUIPMENT

92-12-0080

AERIAL SPECIAL LABELS

Legible, permanent signs shall be installed in positions readily visible to the operator to provide operational directions, warnings, and cautions. The signs shall describe the function of each control and provide operating instructions.

Warning and caution signs shall indicate hazards inherent in the operation of the aerial device. These hazards shall include, but shall not be limited to:

Electrical hazards involved where the aerial device does not provide protection to the personnel from contact with, or near proximity to, an electrically charged conductor.

Toyne Inc.

Electrical hazards involved where the aerial device does not provide protection to ground personnel who might contact the vehicle when in contact with energized electrically charged conductors.

Hazards from stabilizer motion.

Hazards that can result from failure to follow the manufacturer's operating instructions.

AERIAL DEVICE SPECIFICATION PLACARD

A permanent label shall disclose the following information relative to the aerial device:

Make

Model

Serial number

Date of manufacture

Rated capacity (s)

Rated vertical height

Rated horizontal reach

Maximum hydraulic system pressure

Hydraulic oil type and capacity

All other appropriate labels to ensure safe operation of the aerial device shall be permanently affixed in conspicuous locations.

92-12-0130

APPARATUS LEVEL INDICATOR(S)

One (1) bubble type level indicator(s) shall be provided to assist in the aerial device setup. The leveling indicator(s) shall be backlit and color coded indicating the following conditions:

"Green"	Safe Operating Zone.
"Yellow"	Caution Operating Zone.
"Red"	Do Not Operate Zone – Reposition Apparatus.

Toyne Inc.

92-12-0140

FORE/AFT LEVEL

An additional backlit leveling indicator shall be provided and installed to measure fore and aft level of the vehicle.

92-12-0230

AERIAL SIGN PANELS

There shall be a total of two (2) Aerial sign panels provided and installed on the outside of the aerial base section, one (1) each side, for fire department lettering. Each sign panel shall have a lettering surface of approximately 13" wide x 120" long.

92-12-0410

AXE MOUNTING

92-12-0420

There shall be a mount provided and installed for a flat head axe in the fly section of the ladder. The axe mount shall include a receptacle that will cover the entire axe head and a mechanical pin to secure the axe handle.

95-16-2025

The mounting location shall be on the left side.

95-60-1000

FLY SECTION LOAD LIFTING/RAPPELLING EYES

The aerial ladder shall be equipped with two (2) load lifting/rappelling eyes at the tip of the fly section. The load lifting/rappelling eyes, as a pair, shall be rated not to exceed the tip load of the ladder structure.

Toyne Inc.

== '16 75' AERIAL SPRM - 0.000 ==

Drawing file

CORPORATE OWNERSHIP OF MANUFACTURER

The manufacturer of the apparatus must be fully owned and managed by a Parent Company, Corporation, or Individual(s) that is 100% held by United States of America based Company, Corporation, or United States citizen(s).

Proposals from any manufacturer that is fully or partially owned and/or operated by a foreign company, Corporation or Individual(s) under any type of ownership, partnership, or any similar type of agreement will be immediately rejected.

CORPORATE CONTACT INFORMATION

The purchaser shall be provided with the following information to allow them to contact the President/CEO of the manufacturing company (not dealer) when deemed necessary:

- Name of Company President.
- Office address.
- Office telephone number.
- Email address.
- Home address.
- Home telephone number.
- 24/7 Cellular telephone number.

If the manufacturing company is a subsidiary of, division of, or owned by a different Company, the above information shall also be provided on the 'Parent' Company.

There will be no exception to this requirement.

TOP OF THE LINE FIRE APPARATUS

If the manufacturer or bidder for the apparatus manufacturer represents two or more different lines of apparatus and/or operates two or more manufacturing plants, it should be clearly stated in the bid proposal.

In addition to this requirement, the bidder shall give a detailed explanation of why the particular line, brand, model or manufacturing facility will be used.

Manufacturer's or bidder's with multiple lines (two or more) or multiple manufacturing facilities (two or more) shall be required to submit bid proposals on only the top of the line brand/model or from the top of the line facility.

It is the intention of the purchaser to purchase a top of the line, first class, #1 quality fire apparatus. Any bidder that submits a bid on a "lower end" line, brand, model, or from a "lower end" manufacturing facility will be immediately rejected.

The purchaser is not interested in purchasing a manufacturer's or bidders "lower end" apparatus. Because of this, any bids submitted that do not comply with the above requirements will be immediately rejected.

CERTIFICATION OF NFPA 1901-2016 COMPLIANCE

Toyne Inc.

As per NFPA 1901, the Purchaser shall assume the responsibility of determining, prior to the purchase of the apparatus, whom will be responsible for ensuring that all aspects of NFPA 1901 are met. The manufacturer shall be responsible for providing or performing only the items requested by the purchaser in the documents provided to the manufacturer by the purchaser.

Written certification shall be provided by the manufacturer stating that the delivered apparatus complies with the NFPA 1901 Standard. If the purchaser has elected to provide, perform, outsource and/or contract with a third party or waive any item required by NFPA 1901, the manufacturer shall provide, upon delivery, a "Statement of Exceptions" per Chapter 4 of NFPA 1901 4.21.

The "Statement of Exceptions" shall include:

- A separate specification of the section of the NFPA Standard for which the apparatus is lacking compliance.
- A description of the particular aspect of the apparatus that is not compliant therewith or required equipment that is missing.
- A description of the further changes or modifications to the delivered apparatus which must be completed to achieve full compliance.
- An identification of the entity whom will be responsible for making the necessary post-delivery changes or modifications or for supplying and installing any missing required equipment to the apparatus to achieve full compliance to the standard.

Prior to, or at the time of, delivery of the apparatus, the Statement of Exceptions shall be signed by an authorized agent of the entity responsible for the final assembly of the apparatus and by an authorized agent of the purchasing entity, indicating a mutual understanding and agreement between the parties regarding the substance thereof.

The purchaser shall not place the apparatus into active emergency service until fully compliant with NFPA 1901.

NFPA REQUIRED EQUIPMENT

The end user of this apparatus shall provide all other equipment and accessories that are required by NFPA 1901 but not specifically listed in these specifications.

MAXIMUM TOP SPEED

The maximum top speed of this apparatus shall be determined using the following NFPA 1901 Chapter 4 criteria:

- Apparatus with 1250 gallon combined water tank capacity shall not exceed 60 MPH.
- Apparatus with GVWR of over 50,000 lbs. shall not exceed 60 MPH.
- Apparatus weighing over 26,000 lbs. shall not exceed 68 MPH.

HALE MODEL Q-MAX-XS 2,000 GPM SINGLE STAGE PUMP

The fire pump shall be a Hale Fire Pump Company Q-MAX-XS that complies with all applicable requirements of the latest edition of the "Standard for Automotive Fire Apparatus" published by the National Fire Protection Association and printed in Pamphlet 1901.

PUMP WARRANTY

The pump shall be covered by the Hale Pro-Tech 5-year pump warranty against workmanship and materials. Both

Toyne Inc.

parts and labor shall be covered for the first 2 years and years 3-5 shall have parts only coverage.

PUMP PERFORMANCE - 2,000 U.S. GPM.

The pump shall be a single stage centrifugal with a class "A" rated capacity of 2,000 United States gallons per minute. The pump shall deliver the percentage of rated discharge pressures as indicated below:

- 100 percent of rated capacity at 150 pounds net pressure.
- 70 percent of rated capacity at 200 pounds net pressure.
- 50 percent of rated capacity at 250 pounds net pressure.
- 100 percent of rated capacity at 165 pounds net pressure.

PUMP CONSTRUCTION

The entire pump shall be manufactured and tested at the pump manufacturer's factory.

The pump shall be driven by a drive line from the truck transmission. The pump shall be free from objectionable pulsation and vibration under all normal operating conditions. The engine shall provide sufficient horsepower and revolutions per minute to allow the pump to meet or exceed its rated performance.

The entire pump including both suction and discharge passages, shall be hydrostatically tested to a pressure of 500 psi. The pump shall be fully tested at the pump manufacturer's factory to the performance spots as outlined by NFPA 1901.

The pump body and related parts shall be of fine grain alloy cast iron with a minimum tensile strength of 30,000 PSI. All moving parts in contact with water shall be of high quality bronze or stainless steel. Pumps utilizing castings made of lower tensile strength cast iron are not acceptable.

The pump body shall be horizontally split, on a single plane, in two (2) sections, for easy removal of entire impeller assembly including wear rings and bearings from beneath the pump without disturbing piping or the mounting of the pump on the chassis.

The pump shaft shall be rigidly supported by three (3) bearings for minimum deflection. The bearings shall be heavy-duty, deep groove style bearings in the gearbox and they shall be splash lubricated.

The pump impeller shall be of hard, fine grain bronze with a mixed flow design; accurately machined, hand ground, and individually balanced. The vanes of the impeller intake eyes shall be hand ground and polished to a sharp edge, and shall be of sufficient size and design to provide ample reserve capacity utilizing minimum horsepower.

The pump shaft shall be fabricated of heat-treated, electric furnace, corrosion resistant stainless steel, and shall be super finished under the shaft seal. The pump shaft must be sealed with double lip oil seal to keep road dirt and water out of gearbox.

GEAR BOX

Toyne Inc.

The gear box shall be completely manufactured and tested at the pump manufacturer's factory.

The pump gearbox shall be of sufficient size to withstand up to 16,000 lbs. ft. of torque of the engine in both road and pump operating conditions. The gearbox shall be designed of ample capacity for lubrication reserve and to maintain the proper operating temperature.

The gearbox drive shafts shall be of heat-treated chrome nickel steel and shall be a minimum of 2.75 inches in diameter, on both the input and the output drives shafts. The gearbox shall withstand the full torque of the engine in both road and pump operating conditions.

All gears, both drive and pump, shall be of highest quality electric furnace chrome nickel steel. Bores shall be ground to size and the gear teeth shall be crown shaven, and hardened for smooth, quiet running, and a higher load carrying capability. An accurately cut spur design shall be provided to eliminate all possible end thrust.

The pump gear ratio shall be selected by the apparatus manufacturer to give the maximum performance with the engine and transmission selected.

NFPA 2016 INTERLOCK MOULE

An interlock module shall be provided on the pump shift to comply with NFPA shift safety requirements.

GEARCASE COOLING LINE

A cooling line shall be provided in the pump gear case. A line shall be routed from the discharge side of the pump to the gear case, through the gear case then back into the intake side of the pump.

MECHANICAL SEAL

The pump shaft shall be equipped with a single mechanical type seal on the suction (inboard) side of the pump. The mechanical seal shall be a minimum of two inches in diameter and shall be spring loaded, maintenance free and self-adjusting. The mechanical seal shall be constructed of a carbon sealing ring, stainless steel coil spring, Viton rubber cup, and a tungsten carbide seat with Teflon backup seal.

SACRIFICIAL PUMP ANODES

To aid in protecting the pump from internal corrosion, three sacrificial anodes shall be provided and located one in the lower section of each side inlet and one on the discharge side of the pump.

FRC PUMP BOSS PRESSURE GOVERNOR SYSTEM

Fire Research Pump Boss pressure governor and monitoring display kit shall be installed. The kit shall include a control module, pressure sensor, and cables.

The following continuous displays shall be provided:

- Check engine/stop engine warning lights
- Engine rpm shown with four daylight bright LED digits more than 1/2" high

Toyne Inc.

- Engine oil pressure; shown on an LED bar graph display in 10 psi increments
- Engine temperature shown on an LED bar graph display in 10 degree increments
- Battery voltage shown on an LED bar graph display in 0.5 volt increments
- PSI / RPM setting; shown on a dot matrix message display
- PSI and RPM mode LEDs
- Throttle ready LED.

A dot-matrix message display shall show diagnostic and warning messages as they occur. It shall show monitored apparatus information, stored data, and program options when selected by the operator.

The program shall store the accumulated operating hours for the pump and engine, previous incident hours, and current incident hours in a non-volatile memory. Stored elapsed hours shall be displayed at the push of a button. It shall monitor inputs and support audible and visual warning alarms for the following conditions:

- High Engine RPM
- Pump Overheat
- High Transmission Temperature
- Low Battery Voltage (Engine Off)
- Low Battery Voltage (Engine Running)
- High Battery Voltage
- Low Engine Oil Pressure
- High Engine Coolant Temperature

The governor shall operate in two control modes, pressure and RPM. No discharge pressure or engine RPM variation shall occur when switching between modes. A control knob that uses optical technology shall adjust pressure or RPM settings. It shall be 2" in diameter with no mechanical stops, a serrated grip, and have a red idle push button in the center.

A throttle ready LED shall light when the interlock signal is recognized. The governor shall start in pressure mode and set the engine RPM to idle. In pressure mode the governor shall automatically regulate the discharge pressure at the level set by the operator. In RPM mode the governor shall maintain the engine RPM at the level set by the operator except in the event of a discharge pressure increase. The governor shall limit a discharge pressure increase in RPM mode to a maximum of 30 psi. Other safety features shall include recognition of no water conditions with an automatic programmed response and a push button to return the engine to idle.

TFT A-18 INTAKE RELIEF VALVE

A TFT model A-18 intake relief/dump valve shall be provided on the intake side of the pump to relieve excess incoming pressure. The system shall be designed to automatically restore to a non-relieving position when excessive pressure is no longer present. The pressure adjustment range shall be from 50 psi to 200 psi. The relief system shall be adjustable with a common type box end wrench.

The intake relief valve shall be pre-set to 125 psi.

PUMP SHIFT MECHANISM -AIR/ELECTRIC

The pump shall be shifted from road to pump by means of a cab mounted air over electric pump shift switch. The

Toyne Inc.

switch shall have a built in positive locking mechanism to prevent accidental movement of the switch. The locking mechanism shall require the operator to manually lift up on the switch lever to disengage the lock.

The switch shall have three positions:

- Position 1 = road position
- Position 2 = neutral position
- Position 3 = pump position

A green indicator light shall be provided in the driving compartment and shall be energized when the pump shift has been completed. This light shall be labeled "PUMP ENGAGED".

When the apparatus is equipped with an automatic transmission, a green indicator light shall be provided in the driver's compartment. It shall be energized when both the pump shift has been completed and the chassis transmission is in pump gear. This light shall be labeled "OK TO PUMP".

HALE MODEL ESP-PVG OIL LESS PRIMING SYSTEM

A Hale model ESP oil less priming system shall be provided with PVG panel mounted control valve. The priming pump shall be an electrically driven, positive displacement vane type conforming to requirements outlined in NFPA 1901. One priming control shall both open the priming valve and start the priming motor.

The primer shall be capable of taking suction and discharging water with a lift of 10 feet in not more than 30 seconds with the pump dry and using 20 feet of appropriately sized hard suction hose with strainer. The system shall develop a vacuum of 22 inches at an altitude of up to 2,000 feet above sea level. The vacuum test shall be performed with a capped 20-foot length of hard suction hose, developing a vacuum of at least 20 inches with a drop not exceeding 10 inches in 5 minutes.

The environmentally friendly priming system shall not require any priming lubricant.

PRIMER FUSE

The primer shall be protected with a 250 amp fused link to protect the apparatus 12 volt electrical system if the primer motor malfunctions.

MANIFOLD DRAIN VALVE

The pump shall have a manifold type drain valve assembly consisting of a stainless steel plunger in a bronze body with multiple ports. The control for the valve shall be on the left side along the bottom of the panel and above the side running board. The valve shall be a rotary type with a large easy to grip handle. The valve shall be labeled "PUMP DRAIN".

ICI "LEVER LIFT" BLEEDER/DRAIN VALVES

ICI 3/4" quarter turn ball type bleeder/drain valve shall be provided for each discharge and auxiliary intake. A hose shall be connected to the valve that will direct water below the apparatus and away from the immediate pump operator's location.

Toyne Inc.

The control handle shall be "lever lift" style for easy actuation. The handle for the control shall have a recessed area for the color coded identification label.

LOW POINT AUTO-DRAINS

Automatic drains shall be provided in low points of any discharge piping. The drain shall drain to the ground below its location. This drain shall be a supplementary drain and will not be considered the required 3/4" bleeder drain.

6" LEFT (DRIVER) SIDE MASTER INTAKE

A 6" master intake shall be provided on the left (driver) side of the apparatus. The intake shall have a 6" male NST connection. The intake shall have a removable screen to prevent the entry of large objects into the pump. The screen shall be constructed of a material that will provide cathodic protection to the pump. A label shall be provided above the intake that states "DRIVER SIDE MASTER INTAKE". The label shall be color coded burgundy.

SHORTEN SUCTION TUBE - LEFT SIDE

The left side master suction tube shall be shortened for use with externally installed hose appliances keeping the overall apparatus width to a minimum.

LEFT SIDE MASTER INTAKE CAP

A 6" female NST long handle chrome cap shall be provided on the left side master intake.

6" RIGHT (PASSENGER) SIDE MASTER INTAKE

A 6" master intake shall be provided on the right (passenger) side of the apparatus. The intake shall have a 6" male NST connection. The intake shall have a removable screen to prevent the entry of large objects into the pump. The screen shall be constructed of a material that will provide cathodic protection to the pump. A label shall be provided above the intake that states "PASSENGER SIDE MASTER INTAKE". The label shall be color coded burgundy.

SHORTEN SUCTION TUBE - RIGHT SIDE

The right side master suction tube shall be shortened for use with externally installed hose appliances keeping the overall apparatus width to a minimum.

RIGHT SIDE MASTER INTAKE CAP

A 6" female NST long handle chrome cap shall be provided on the right side master intake.

FRONT BUMPER INTAKE

A front bumper intake shall be provided and located on the right side of the front bumper.

Toyne Inc.

HALE MIV-E MASTER INTAKE VALVE FOR FRONT INTAKE

The front intake shall be equipped with a Hale model MIV-E electrically operated intake valve. The valve shall be a full flow butterfly type valve designed to mount on the fire pump between the suction tube extension and the suction tube behind the pump panel. The valve shall not interfere with other suction or discharge openings on the fire pump or with the operating control properly mounted.

The entire valve shall be cast, manufactured, and tested at the pump manufacturer's factory. The valve body and related components that are in contact with water shall be fine grained corrosion resistant bronze. The butterfly disc shall be manufactured of 80,000 psi minimum yield strength heat treated cast steel then coated with a durable nitrile rubber to provide a positive seal when the valve is closed. The valve shall be hydrostatically tested to 600 psig and vacuum tested to 26" hg.

A pressure relief valve shall be provided that is factory set at 125 psi and field adjustable from 75 to 250 psi. The pressure relief valve shall provide overpressure protection for the soft suction hose even when the intake valve is closed.

The inlet valve shall be operated by a 12 VDC electric motor with the control on the pump panel. The valve shall be provided with panel placards indicating control operation. The placards shall have status lights to indicate whether the valve is open, closed, or traversing from one position to the other. The valve shall have a gear operator that will open/close the valve in no less than 3 seconds. The gear actuators shall be sealed to provide reliable service in the hard pump compartment environment. The ratio of the actuator will be such that the handwheel will close the valve in no more than 10 complete turns.

A label stating the following will be provided near the intake: "WARNING-SERIOUS INJURY OR DEATH COULD OCCUR IF INLET IS SUPPLIED BY A PRESSURIZED SOURCE WHEN THE VALVE IS CLOSED."

MANUAL MIV "BACKUP" CONTROL - FRONT INTAKE

A manually operated "backup" handwheel control shall be provided for the front intake valve and located in an accessible location. Because the backup control moves when the electric control is activated, the backup control shall not be located in any location that firefighting personnel may come into contact with the control during normal operations.

FRONT MIV VALVE DRAIN

A 3/4" drain shall be provided on the valve body to allow draining of the outer side of the valve.

FRONT MIV BLEEDER VALVE

A 1/4" bleeder valve shall be provided on valve body to bleed off air on the outer side of the valve.

FRONT INTAKE SWIVEL CONNECTION

A **chrome plated** front suction swivel elbow with 6" MNST thread shall be provided. The elbow shall have a vertical lock to prevent vacuum leaks due to side loads and shall have dual o-rings for a positive seal. The elbow, as well as the swivel bearings, shall be brass for increased durability. A built in strainer shall also be included with the elbow.

Toyne Inc.

FRONT MASTER INTAKE CAP

A 6" female NST long handle chrome cap shall be provided on the front master intake.

3/8" PUMP COOLING/BYPASS LINE

A 3/8" pump cooling/bypass line shall be provided from the pump discharge manifold directly into the tank.

This discharge shall implement an all brass ball type 1/4 turn valve with chrome plated handle control located on the pump panel.

The valve control handle shall indicate the open/closed position of the valve. The handle shall have a recessed area for mounting of the identification label which shall clearly state "PUMP COOLER".

TANK REFILL/RECIRCULATION DISCHARGE

A discharge shall be provided from the pump discharge manifold to allow pump cooling when necessary as well as to refill the booster tank.

The water tank fill gauge shall be directly in line with this discharge control.

The valve and piping shall be 2".

The refill/recirculation discharge shall be manually controlled on the pump panel.

STAINLESS STEEL PIPING

All piping for discharges shall be stainless steel using stainless steel fittings. High pressure helix wire reinforced flexible piping with a minimum burst pressure of 1200 psi may be used in some areas to minimize friction losses. All flexible piping couplings shall be high tensile strength stainless steel.

All piping shall be properly supported and braced to prevent movement of piping other than what is allowed by the flexible couplings to compensate for apparatus flexing.

Any discharge manifolds provided on the apparatus must be fabricated of a minimum of schedule 10 304 marine grade piping. Use of any welded light gauge (less than Schedule 10) manifolding or plumbing will not be acceptable.

The stainless steel piping shall be warranted to be free from corrosion perforation for a period of 10 years following the delivery of the apparatus.

VICTAULIC COUPLINGS

Victaulic style couplings shall be used in the assembly of the pump piping system. The couplings shall allow flex in the piping and provide for a disassembly point for maintenance and repairs.

VENTED LUG CAPS AND PLUGS

Toyne Inc.

All intake and discharge plugs and caps and plugs shall be vented lug type designed to relieve trapped pressure and help reduce possible operator injuries.

AKRON HD-8800 SERIES VALVES

All discharge and small diameter auxiliary intakes shall have heavy duty Akron 8800 series brass ball valves with stainless steel ball. This shall include the tank to pump and tank fill valve.

RIGHT SIDE FORWARD AUXILIARY INTAKE

An auxiliary intake shall be provided on the right side of the pump compartment in the forward position.

The valve control shall be manually controlled at the intake location.

The intake shall have a 2 1/2" chrome plated female NST swivel connection with screen and a male NST chrome plated intake plug and chain.

A 3/4" bleeder/drain valve shall be provided.

FUTURE FOAM CAPABILITIES

The apparatus shall be pre-piped for future installation of a foam system. The manifold shall be stainless steel. This manifold shall be fed from the main pump discharge manifold and shall have a spacer pipe installed between the two manifolds with Victaulic couplings on each end. The spacer pipe shall be the length required for future installation of an electronic foam system.

To minimize the future costs of installing foam on the apparatus, there shall be no exception to this requirement.

AERIAL WATERWAY 4" DISCHARGE

One 4" discharge shall be provided from the pump to feed the aerial device.

The discharge shall be manually controlled from the pump operator's position with a gear actuated handwheel control featuring position indication.

WATERWAY RELIEF VALVE

One 3/4" relief valve shall be installed above the butterfly valve.

REAR AERIAL INTAKE

There shall be a 4" intake installed on the rear of the apparatus to be used for supplying the aerial waterway from an external source.

The intake connection shall be a 4" MNST chrome fitting.

Toyne Inc.

AERIAL INTAKE CAP - 4"

A 4 FNST-LHF chrome cap shall be provided on the external feed aerial intake.

WATERWAY DRAIN VALVE

A 1 1/2" drain valve shall be installed in the lower section of the aerial plumbing under the truck. The valve, when opened, shall drain the aerial waterway and lower plumbing.

RIGHT SIDE DISCHARGES

One 2 1/2" discharge and one 4" discharge shall be provided on the right side pump panel. The 4" discharge shall be located forward of the intake and the 2 1/2" shall be located rear of the intake.

One (1) right side 2 1/2" discharge(s):

The right side 2 1/2" discharge shall be manually controlled on the pump panel.

The discharge shall be equipped with a chrome plated brass or bright finish stainless steel discharge elbow with 2 1/2" MNST thread.

A 2 1/2" chrome plated NST cap and chain shall be provided.

One (1) right side 4" discharge(s):

The right side 4" discharge shall be manually controlled from the pump operator's position with a gear actuated hand wheel control featuring position indication.

The discharge shall extend straight out of the apparatus with no elbow.

A 4" chrome plated NST discharge cap shall be provided.

LEFT SIDE DISCHARGE

One 2 1/2" discharge shall be provided on the left side pump panel. The discharge shall be located forward of the intake.

One (1) left side 2 1/2" discharge(s):

The left side 2 1/2" discharge shall be manually controlled on the pump panel with a horizontal side-to-side lever control.

The discharge shall be equipped with a chrome plated brass or bright finish stainless steel discharge elbow with MNST thread.

A 2 1/2" chrome plated NST cap and chain shall be provided.

1 3/4" CROSSLAY PRECONNECTS

Toyne Inc.

Two 1 3/4" preconnected crosslays shall be provided and located above the side mount pump panel.

The crosslay compartment shall be constructed of 5052 smooth aluminum sheet material with a random brushed finish applied after fabrication. Each crosslay shall be piped using 2" piping or high pressure hose incorporating a 2" ball valve with the control on the side mount pump operator's panel.

The #1 - hand line crosslay shall have the capacity to hold 200 feet of 1 3/4" or 2" fire hose and nozzle.

The #2 - hand line crosslay shall have the capacity to hold 200 feet of 1 3/4" or 2" fire hose and nozzle.

The valve(s) shall be manually controlled on the pump panel.

There shall be two (2) 2" swivel elbows with 1 1/2" male NST hose thread connections provided on the cross lay hose beds. The swivels shall be mounted in a position to prevent hose "pinching" at the hose thread connection.

3/4" manual drain valves shall be provided for all 1 3/4" crosslays. The valves shall have an all brass body with heavy duty neoprene seal.

The #1 hand line crosslay shall be pre-piped for future foam system installation.

The #2 hand line crosslay shall be pre-piped for future foam system installation.

2 1/2" CROSSLAY PRECONNECT(S)

One (1) 2 1/2" pre-connected crosslay(s) shall be provided and located above the side mount pump panel.

The crosslay compartment shall be constructed of 5052 smooth aluminum sheet material with a random brushed finish applied after fabrication. Each crosslay shall be piped using 2 1/2" piping or high pressure hose incorporating a 2 1/2" ball valve with the control on the side mount pump operator's panel.

The #1 - 2 1/2" crosslay shall have the capacity to hold 150 feet of 2 1/2" or 3" fire hose and nozzle.

The valve(s) shall be manually controlled on the pump panel.

There shall be one (1) 2 1/2" swivel elbow with a 2 1/2" male NST hose thread connection provided on the 2 1/2" cross lay hose bed. The swivel shall be mounted in a position to prevent hose "pinching" at the hose thread connection.

The #1 2 1/2" crosslay shall be pre-piped for future foam system installation.

3/4" manual drain valves shall be provided for all 2 1/2" crosslays. The valves shall have an all brass body with heavy duty neoprene seal.

VINYL CROSSLAY COVER

Toyne Inc.

A vinyl cover shall be provided to cover the crosslay compartment.

VINYL CROSSLAY COVERS - RED

Red vinyl coated nylon end covers shall be provided to cover the ends of the crosslays.

1 3/4" FRONT BUMPER DISCHARGE(S)

There shall be one (1) 1 3/4" discharge(s) provided on the front of the apparatus. Piping and valve shall be 2".

The valve shall be manually controlled on the pump panel.

The front bumper 1 3/4" discharge shall be pre-piped for future foam system installation.

The front bumper discharge shall have a 1 1/2" MNST thread connection.

FRONT DISCHARGE HOSE CONNECTION - CHROME SWIVEL

The hose connection for the discharge shall be located immediately adjacent to the hosewell. A **chrome plated or polished stainless steel** swivel shall be provided. The lid for the hosewell shall be notched to allow for the hose to be preconnected.

FRONT BUMPER DISCHARGE HOSE CONNECTION - DRIVER'S SIDE

The hose connection for the front bumper discharge shall be on the driver's side.

PUMP COMPARTMENT

A modular pump compartment with side mounted pump operator's panel shall be provided. The modular design of the pump compartment shall allow the compartment to be fully independent of the apparatus body. A 1" flex joint shall be provided between the pump compartment and the apparatus body.

The modular design of the pump compartment shall allow the entire pump system, including the pump itself, to be removed from the apparatus in a one-piece assembly while leaving the body intact and without having to cut any sheet metal or welds.

STAINLESS STEEL PUMP COMPARTMENT CONSTRUCTION

The entire pump compartment shall be constructed using only 304 marine grade stainless steel fabricated sheeting with a #4 annealed and polished finish on all exterior surfaces. The pump compartment shall not require any finish painting. Due to the extreme twisting and flexing that all fire apparatus are subjected to, aluminum shall not be used in any portion of the pump compartment structural support. The use of any type of enclosed tubing that requires the use of self tapping or any other type of machine screw shall not be acceptable.

PUMP COMPARTMENT WIDTH – 56”

Toyne Inc.

The pump compartment shall be 56" from the forward wall to the rear wall. This shall include the entire pump compartment as well as any components such as the ladder cradle, hydraulic system, etc.

PUMP COMPARTMENT RUNNING BOARDS

The pump compartment side running boards shall be constructed of NFPA compliant slip resistant aluminum treadbrite.

PUMP OPERATOR'S PLATFORM

A pull out pump operator's platform shall be provided at the pump operator's control panel. The platform shall be designed to support a minimum of 500 pounds. The top surface shall be constructed of NFPA aluminum treadbrite with "raised grip" knurled serrations for slip resistance. The platform shall be 18" deep x 40" wide. The platform shall lock in both the retracted and extended positions.

PUMP COMPARTMENT FRONT WALL

The front wall of the pump compartment shall be constructed of aluminum treadbrite which is bolted to the pump compartment assembly and removable.

PUMP COMPARTMENT RIGHT SIDE ACCESS DOOR - SIDE MOUNT

A brushed stainless steel hinged access door shall be provided on the right side of the pump compartment. The doors shall have pneumatic hold open devices and push button type flush latches.

SIDE MOUNT BRUSHED STAINLESS STEEL PUMP PANEL

All controls and instruments shall be located on the left side of the apparatus. All discharge and intake valve controls shall be located on the left side pump panel.

BRUSHED STAINLESS STEEL PUMP PANELS

The left and right side pump panels shall be constructed of 304 2B marine grade brushed stainless steel with a #4 brushed and polished finish. The panels shall be held into place with two latches on the top to allow for easy removal of the panels.

The upper section of the left side pump panel shall be constructed of the same 304 2B marine grade stainless steel. The upper section shall be vertically hinged and have a chrome plated latch to secure the panel when closed.

LED SIDE MOUNT PUMP PANEL LIGHTS

The side mount pump panel shall be illuminated using a track type LED light assembly.

The light shall be constructed of an unbreakable type clear poly flexible material housed in an aluminum extrusion mounted behind a brushed stainless steel light shield provided across the top of the gauge panel.

Toyne Inc.

LED RIGHT SIDE DISCHARGE/INTAKE PANEL LIGHTS

The right side discharge and intake panels shall be illuminated using a track type LED light assembly.

The light shall be constructed of an unbreakable type clear poly type flexible material housed in an aluminum extrusion mounted behind a brushed stainless steel light shield provided across the top of the hinged access door.

AUTOMATIC PUMP PANEL LIGHT ACTIVATION

The pump panel lights above the pump control panel shall function automatically with the pump shift activation.

PUSH/PULL VALVE CONTROL HANDLES

The apparatus pump panel shall be equipped with Innovative Controls side mount valve controls to open/close the manually operated discharge valves.

The ergonomically designed ¼ turn push-pull T-handle shall be chrome plated zinc with recessed labels for color coding and verbiage. The control rod shall provide a true positive lock to eliminate valve drift. Bronze and Teflon impregnated stainless steel bushings in both ends of rod housing shall minimize rod deflection, never need lubrication, and ensure consistent long term operation.

The control assembly shall include a decorative chrome plated zinc panel mounting bezel.

DISCHARGE VALVE CONTROL HANDLE LAYOUT

All discharge valve control handles shall be located in one or two horizontal lines across the mid-section of the pump panel. The control handles shall be located immediately below their corresponding pressure gauge for ease of pump operation.

STAINLESS STEEL VALVE CONTROL LINKAGES

All manual valve controls shall have control rod linkages constructed of 1/2" stainless steel rod or pipe and shall implement heavy ball swivel joints and clevises for smooth valve operation.

Steel, painted or coated control rods are not acceptable. (No Exception).

ICI MASTER PUMP DISCHARGE PRESSURE GAUGE

An ICI 4" diameter master pressure gauge shall be provided to indicate the main pump discharge pressure. The gauge shall read from 30" hg vacuum to 400 psi and shall be accurate within +/- 1%. The gauge shall be glycerin filled (-40F to +150F) and have a high impact resistant clear acrylic lens.

ICI MASTER PUMP INTAKE PRESSURE GAUGE

An ICI 4" diameter master pressure gauge shall be provided to indicate the pump intake pressure. The gauge shall

Toyne Inc.

read from 30" hg vacuum to 400 psi and shall be accurate within +/- 1%. The gauge shall be glycerin filled (-40F to +150F), read up to 400 psi, be accurate within +/- 1% and have a high impact resistant clear acrylic lens.

The master intake and discharge gauges shall have bright finish stainless steel bezels.

The master gauge dials shall be white with black markings. The needle shall match the color of the markings.

The master intake gauge shall be clearly labeled "PUMP INTAKE" and shall be located to the left of the master discharge pressure gauge. The label shall be burgundy color.

The master discharge gauge shall be clearly labeled "PUMP DISCHARGE" and shall be located to the right of the intake pressure gauge. The label shall be black color.

The master intake/discharge pressure gauges shall have a lifetime non-yellowing and freeze warranty. The gauges shall also be warranted for 4 years for defects in materials and workmanship, including fluid leakage. The warranty will not cover labor costs and/or transportation costs.

PRESSURE/VACUUM TEST PLUGS

Underwriter's test plug adapters shall be provided for connection of pump test gauges.

INNOVATIVE CONTROLS SL PLUS TANK GAUGE - PUMP PANEL

An Innovative Controls model SL Plus tank gauge shall be provided on the pump panel. The gauge shall feature a 180 degree highly visible wide view ultra-bright LED display showing the level of the booster tank.

TANK GAUGE PARK BRAKE DISABLE

The tank gauge(s) shall be disabled when the park brake is released so that the lights are not a distraction when the vehicle is in motion.

ICI DISCHARGE PRESSURE GAUGES

Unless otherwise specified, each 1 1/2" or larger discharge shall have an ICI pressure gauge. The gauge shall be glycerin filled (-40F to +150F), read from 0 - 400 psi, be accurate within +/- 1% and have a high impact resistant clear acrylic lens.

The individual discharge pressure gauges shall have a 2 3/4" diameter.

The discharge pressure gauge dials shall be white with black markings. The needle shall match the color of the markings.

The pressure gauge shall be directly in line with the discharge control handle for the discharge that they provide pressure readout for. **For ease of operation, this requirement must be strictly adhered to. There shall be no exception to this requirement.**

The gauges shall be clearly labeled with permanent color coded labels.

The discharge pressure gauges shall have a lifetime non-yellowing and freeze warranty. The gauge shall also be warranted for four years for defects in materials and workmanship including fluid leakage. Warranty will not cover

Toyne Inc.

labor costs and/or transportation costs.

IDENTIFICATION LABELS FOR PUMP PANEL

Innovative Controls verbiage label bezels shall be installed. The bezel assemblies will be used to identify apparatus components. These labels shall be designed and manufactured to withstand the specified apparatus service environment.

Where required, the verbiage label bezel assemblies shall include a chrome plated panel mount bezel with durable easy to read UV resistant polycarbonate inserts featuring the specified verbiage and color coding. The UV resistant polycarbonate verbiage and color inserts shall be sub-surface screen printed to eliminate the possibility of wear and protect the inks from fading. Both the insert labels and bezel shall be backed with 3M permanent adhesive (200MP), which meets UL969 and NFPA standards.

The color scheme for the discharge and intake labels shall be per NFPA A.16.9.1.

BOOSTER TANK- UNITED PLASTIC FABRICATING, INC.

The tank shall have a LIFETIME warranty provided by United Plastic Fabricating, Inc.

The tank shall be constructed of 1/2" thick PT2E polypropylene sheet stock. This material shall be non-corrosive stress relieved thermo-plastic, natural in color and U.V. stabilized for maximum protection. The booster tank shall be of a specific configuration and is so designed to be completely independent of the body and compartments. All joints and seams shall be nitrogen welded and tested for maximum strength and integrity. The top of the booster tank is fitted with removable lifting eyes designed with a 3 to 1 safety factor to facilitate easy removal.

The transverse swash partitions shall be manufactured of 3/8" PT2E polypropylene material. The longitudinal swash partitions shall be constructed of 3/8" PT2E polypropylene and extend through the cover to allow for positive welding and maximum integrity. All partitions shall be equipped with vent and air holes to permit movement of air and water between compartments. The partitions shall be designed to provide maximum water flow. All swash partitions shall interlock with one another and are welded to each other as well as to the walls of the tank.

The tank cover shall be constructed of 1/2" thick PT2E polypropylene, natural in color, stress relieved, UV stabilized material and shall incorporate a three piece locking design which will allow for individual removal of each section of necessary. The tank cover shall be recessed 3/8" from the top of the tank and shall be welded to both sides and longitudinal partitions of maximum integrity. Each of the covers shall have hold downs consisting of 2" polypropylene dowels spaced a maximum of 30" apart. These dowels shall extend through the covers and will assist in keeping the covers rigid under fast filling conditions. A minimum of two lifting dowels shall be drilled and tapped to accommodate the lifting eyes.

The sump shall be constructed of 1/2" PT2E polypropylene. The sump shall have a 3" NPT threaded outlet on the bottom for a drain plug. An anti-swirl plate shall be located approximately 2 1/2" above the sump.

The tank cradle assembly shall be designed to provide support to the tank. The assembly shall be approved by the manufacturer of the tank.

Toyne Inc.

BOOSTER TANK CAPACITY 400 GALLONS

The poly booster tank shall have a capacity of 400 U.S. gallons.

BOOSTER TANK FILL TOWER - LEFT SIDE FRONT

The tank shall have a combination vent and manual fill tower. The fill tower shall be constructed of 1/2" polypropylene and shall be a minimum of **10" x 10"** outer dimension. The tower shall be located in the left front corner of the hose bed. The tower shall have a 1/4" thick removable polypropylene screen and polypropylene hinged type cover.

4" TANK OVERFLOW

A 4" diameter tank vent/overflow shall be provided and integrated into the tank. The piping shall be a minimum of schedule 40 polypropylene designed to run through the tank and discharge behind the rear wheels.

25 GALLON CLASS A FOAM TANK

A 25 gallon Class A foam tank shall be provided. The tank shall have all connections necessary to connect to the foam system and shall also have a 1/4 turn drain valve with hose attached to allow the tank to be drained.

The tank shall have an **8" x 8"** fill tower with hinged type lid with latch. A vent shall be provided in the lid.

A label shall be provided on the lid that reads "CLASS A FOAM TANK FILL" and "WARNING: DO NOT MIX BRANDS OR TYPES OF FOAM".

CLASS A FOAM TANK/BOOSTER TANK INTEGRATION

The class A foam tank shall be integrated into the apparatus booster tank. The foam tank shall not be separate from the booster tank.

3" TANK TO PUMP

One 3" tank to pump line(s) and valve(s) shall be provided between the tank and the pump. The piping from the sump to the valve shall be 4".

The tank to pump valve shall be manually controlled on the pump panel.

TANK TO PUMP CHECK VALVE

A check valve assembly shall be provided on the pump. The valve shall prevent unintentional back filling of the tank through the tank to pump line. Connection from the valve to the tank shall be made by using a non-collapsible flexible rubber hose.

HOT DIPPED GALVANIZED SUB FRAME

Toyne Inc.

The tank cradle and body substructure shall be constructed of high strength ASTM A-36 structural steel with a 36,000 psi minimum yield strength. The entire substructure shall be framed and jig welded together to insure a truly square assembly. The substructure shall be fastened to the chassis rails so that it may be easily removed from the chassis for repair, replacement or mounting to a new chassis.

After complete assembly of the tank cradle substructure, the entire assembly shall be hot dipped galvanized for superior corrosion protection.

Due to the extreme duty that this apparatus will experience during its intended service life and to prevent rusting and corrosion from shortening the service life of this apparatus, sub frames fabricated of painted/undercoated steel or aluminum tubing shall not be acceptable.

20 YEAR SUB-STRUCTURE WARRANTY

The tank cradle and body substructure shall have a 20 warranty covering failure due to corrosion perforation or structural design error.

This warranty shall be in effect for 20 years after delivery of the apparatus to the customer. **NO EXCEPTION.**

HYPER-FLEX BODY MOUNTING

The body module assembly shall be mounted to the chassis frame rails with "*Hyper-Flex*" vibration and shock isolators using a forward mounting system. Flexible neoprene pads, or U-springs especially developed for the expected weight and torsional flexing of the apparatus body, shall be incorporated into the system to eliminate chassis frame rail flex from transmitting harmful loads and twisting onto the body.

APPARATUS BODY MATERIAL

The entire apparatus body shall be constructed of 304 marine grade stainless steel with a #4 annealed and polished finish. The interior of the apparatus body shall not require any finish painting. The compartment interiors must be a #4 finish. Mill finish or DA sanded finish will not be acceptable.

APPARATUS BODY CONSTRUCTION

The entire apparatus body shall be formed by sheering and bending the sheet metal. Metal tubular structures or extrusions shall not be used in the construction of the apparatus body. All edges of the sheared metal shall be sanded to remove any sharp shearing edges prior to bending the metal. After sheering and bending, the body shall be assembled on a jig table that is designed to hold all parts securely in place to insure an accurately built apparatus body.

APPARATUS BODY ASSEMBLY METHOD

The entire apparatus body shall be assembled using only bolted type construction. All apparatus body parts shall be able to be unbolted without the need to cut welds, etc. No exceptions to this requirement as all apparatus manufacturers have the capability to manufacture apparatus bodies in this manner.

COMPARTMENT FLOORS

Toyne Inc.

All compartment floors shall be constructed of 304 marine grade stainless steel with a # 4 annealed and polished finish on the interior surface. The drain ports shall be designed to prevent road spray from entering the compartment. The front edge shall consist of a minimum of two bends to provide additional strength in the compartment floor and shall then form the lower door jamb.

All compartment floors shall be sweep out design. This shall include the lower side compartments, any compartments above the wheel well, any transverse compartments, and the rear face compartment(s). Any exception to this requirement will cause immediate rejection of bid.

COMPARTMENT WEIGHT RATING

Each compartment shall be designed to carry 1,000 lbs. of equipment distributed throughout the compartment.

INTERIOR COMPARTMENT SURFACES

All visible interior compartment surfaces shall be 304 marine grade stainless steel with a # 4 annealed and polished finish. Surfaces that are painted or coated in any manner, raw material or any surface with any type sanded finish are not acceptable.

FRONT COMPARTMENT CORNERS

The apparatus body front compartment corners and vertical faces on both sides shall be constructed of 304 marine grade stainless steel with a # 4 annealed and polished finish. The corners shall be a one-piece fabrication from top to bottom and from the inner body panel to the outer face of the compartment to provide maximum strength. Corners using structural support channels or extrusions that require two or more pieces shall not be implemented.

The # 4 finish corner shall wrap around the side of the apparatus body and form the front compartment door jamb providing front corner protection.

REAR COMPARTMENT CORNERS - BRUSHED

The apparatus body rear compartment corners and vertical faces on both sides shall be constructed of 304 marine grade stainless steel with a # 4 annealed and polished finish. The corners shall be a one-piece fabrication from top to bottom and from the inner body panel to the outer face of the compartment to provide maximum strength. Corners using structural support channels or extrusions that require two or more pieces shall not be implemented.

The # 4 finish corner shall wrap around the side of the apparatus body and form the rear compartment door jamb providing front corner protection.

COMPARTMENT TOPS/CEILINGS

The apparatus body compartment tops shall be constructed of 304 marine grade stainless steel with a # 4 annealed and polished finish on the interior surface.

COMPARTMENT TOP OVERLAY

Toyne Inc.

The compartment top shall be overlaid with 1/8 aluminum treadbrite. The aluminum treadbrite shall be an overlay only and shall not form any structural part of the apparatus body or shall the bottom side of the treadbrite be visible when looking into the compartment.

PAINTED FENDERWELLS

The left and right side rear fender wells shall be constructed of ultra-smooth 304 marine grade stainless sheet steel with a minimum tensile strength of 90,000 psi. The fender wells shall be radius cut and shall have a full circular inner liner to prevent rust pockets and for ease of cleaning. A 1" gap shall be provided on the bottom of each side of the circular liner to allow drainage of water and for easy cleanout. Sufficient clearance shall be provided for tire chains. Before the booster tank is installed, the fender wells shall be thoroughly cleaned and all seams sealed to prevent corrosion in the fender well area.

PAINTED FENDERWELLS

The fender wells shall be finish painted the primary exterior color of the apparatus.

REMOVABLE INNER FENDER LINER

The fender wells shall be radius cut and shall have a circular inner liner to prevent corrosion pockets and for ease of cleaning. The inner liner shall be constructed of high impact polypropylene material and shall be fully removable for chassis suspension access.

To prevent the accumulation of potential corrosive materials in the fender well area, there shall be no exception to the removable inner fender liner.

STAINLESS STEEL FENDERETTE

The fender wells shall be trimmed with a polished stainless steel fenderette. The stainless steel fenderette shall be secured into place with stainless steel fasteners and shall be easily removable for replacement. A black rubber fender welting shall be provided between the fenderette and the inner liner surface. The fenderettes shall protrude from the apparatus body a maximum of 1".

REPLACEABLE FENDERETTE

The stainless steel fenderette shall be secured to the apparatus body with stainless steel fasteners and shall be easily removable for replacement.

Fenderettes that are welded to the apparatus body are not acceptable.

OUTER BODY SIDES

The outer left and right side body panels above the compartment tops shall be constructed of 304 2B marine grade stainless steel with a # 4 brushed finish and shall not require any finish paint.

COMPARTMENT VENTILATION

Toyne Inc.

Each compartment shall have a removable metal ventilation plate to allow for air movement in the compartment. A cleanable filter material shall be provided behind the plate.

Plastic cover plates will not be acceptable.

ROM SERIES IV ROLL UP COMPARTMENT DOORS

For all compartments requiring roll up doors, Robinson (ROM) Series IV roll up doors shall be installed.

Each shutter slat, track, bottom rail, and drip rail shall be constructed from anodized 6063 T6 aluminum.

The shutter slats shall feature a double wall extrusion 0.315" thick with a concave interior surface to minimize loose equipment jamming the shutter door closed. Shutter slats shall feature an interlocking end shoe to prevent side to side binding of the shutter door during operation. Slat must have interlocking joints with an inverted locking flange. The slat inner seal shall be a one piece PVC extrusion designed to prevent metal to metal contact while minimizing dirt and water from entering the compartment.

The shutter door tracks shall be one piece design with integral overlapping flange to provide a clean finished look without the need of caulk. Door tracks shall feature an extruded Santoprene rubber double lip low profile side seal with a silicone co-extruded back to reduce friction during shutter operation.

The shutter bottom rail shall be a one piece double wall extrusion with integrated finger pull. The finger pull shall be curved upward with a linear striated surface to improve operator grip while operating the shutter door. The bottom rail shall have a smooth contoured interior surface to prevent loose equipment from jamming the shutter door. Bottom rail seal shall be made from Santoprene and shall be a double "V" seal to prevent water and debris from entering compartment. The bottom rail lift bar shall be a one piece "D" shaped aluminum extrusion with linear striations to improve operator grip during operation. The lift bar shall have a wall thickness of 0.125" and be supported by no less than two pivot blocks constructed from Type 66 Glass filled reinforced nylon for superior strength. The bottom rail end blocks shall have incorporated drain holes which will allow any moisture that collects inside the extrusion to drain out.

Shutter door shall have an enclosed counter balance system. The system shall be 4" in diameter and held in place by 2 heavy duty 18 gauge zinc plated plates. The counter balance system shall have 2 over-molded rubber guide wheels to provide a smooth transition from vertical track to counter balance system; no foam material of any kind shall be permitted or used in this area.

STAINLESS STEEL COATED FASTENERS

All fasteners used in the finish construction of the apparatus body shall be marine grade stainless steel. Fasteners that pass through a dissimilar metal panel shall be Magna-Gard, or equal, coated to help prevent metal reaction and corrosion.

As the Magna-Gard, or equal, coating is a "baked on" type coating providing for excellent adhesion to the fastener, spray on type coatings may be used in conjunction with the Magna-Gard, or equal, but not in place of it.

Because dissimilar metal corrosion is a common occurrence on all apparatus and the Magna-Gard (or similar "baked on" coatings) fasteners are commercially available to all manufacturers and is not a proprietary product, there shall be no exception to this requirement.

DRIVER'S SIDE COMPARTMENT AHEAD OF REAR WHEELS

A compartment shall be provided in front of the rear wheels on the driver's side. The interior compartment dimensions

Toyne Inc.

shall be 67" high x 63" wide x 24" usable depth in lower section and 14" useable depth in the upper section.

The compartment shall have a roll up door with satin finish.

DRIVER'S SIDE COMPARTMENT ABOVE REAR WHEELS

A compartment shall be provided above the rear wheels on the driver's side. The interior compartment dimensions shall be 28" high x 42" wide x 14" useable depth.

The compartment shall have a roll up door with satin finish.

DRIVER'S SIDE COMPARTMENT ABOVE REAR WHEELS

A compartment shall be provided above the rear wheels on the driver's side. The interior compartment dimensions shall be 28" high x 42" wide x 14" useable depth.

The compartment shall have a roll up door with satin finish.

DRIVER'S SIDE COMPARTMENT BEHIND REAR WHEELS

A compartment shall be provided behind the rear wheels on the driver's side. The interior compartment dimensions shall be 61" high x 52" wide x 22" usable depth in lower section and 14" useable depth in the upper section.

The compartment shall have a roll up door with satin finish.

PASSENGER'S SIDE COMPARTMENT AHEAD OF REAR WHEELS

A compartment shall be provided in front of the rear wheels on the passenger's side. The interior compartment dimensions shall be 67" high x 63" wide x 24" usable depth in lower section and 14" useable depth in the upper section.

The compartment shall have a roll up door with satin finish.

PASSENGER'S SIDE COMPARTMENT BEHIND REAR WHEELS

A compartment shall be provided behind the rear wheels on the passenger's side. The interior compartment dimensions shall be 29" high x 52" wide x 22" usable depth.

The compartment shall have a roll up door with satin finish.

RUBRAILS - BRIGHT ANODIZED ALUMINUM

Extruded aluminum rub rails shall be provided on the apparatus body sides. The rub rails shall have a bright finish with anodized coating to protect the finish. The rub rails shall be spaced from the apparatus body a minimum of 1/4" with poly spacers.

Toyne Inc.

The rub rails must be bolted on to the apparatus body to allow easy replacement if damaged. Rub rails that are permanently fastened to the apparatus body by welding or any other permanent method will not be acceptable. **NO EXCEPTION WILL BE ALLOWED TO THIS REQUIREMENT.**

RUB RAIL ENDS

The rub rail ends shall be 'capped' with a high impact resistant black EPDM contoured block.

HOSE BED

The hose bed shall be located to the right side of the turntable support structure above the right rear side low compartment extending over the right side wheel well.

The hose bed shall extend backward, past the right side of the turntable support, and exit at the rear of the apparatus. The access shall be free of obstructions that may interfere with the deployment and loading of hose.

The hose bed shall be a minimum of 24" wide x 29" high x 138" depth. A minimum of 57 cubic feet of hose bed space shall be provided.

HOSE BED FLOORING

The floor of the hose bed shall be constructed of 1/8" smooth aluminum with drainage slots.

HOSE BED COVER WITH VELCRO FASTENERS

A heavy duty vinyl coated nylon hose bed cover shall be provided to protect the hose load from the weather. The cover shall extend from the front of the hose bed to the rear and then extend downward to cover the exposed rear of the bed.

The cover shall have a double reinforced area where the cover comes into contact with the upper rear corners of the hose bed dividers. The cover shall be secured to the apparatus using Velcro on the sides and lift dots on front.

The rear of the cover shall be secured to the apparatus using positive mechanical latches.

HOSE BED COVER - RED

The hose bed cover shall be red.

GROUND LADDER STORAGE COMPARTMENT

A storage compartment shall be provided on the rear of the apparatus inside the aerial torque box. The compartment shall have individual slides for each ladder to allow individual removal of ladders. The individual slides shall be lined with a slip material to allow easy removal of the ladders. The ladder storage rack shall be a one piece assembly which is easily removable from the torque box without disassembly.

A satin finish roll up door shall be provided on the rear of the ladder compartment to enclose the ladders.

Toyne Inc.

PIKE POLE STORAGE COMPARTMENT

A pike pole storage compartment shall be provided on the rear of the apparatus inside the aerial torque box. The compartment shall have individual tubes for each pike pole. The tubes shall be constructed of PVC or aluminum.

DUO SAFETY 35' 3-SECTION ALUMINUM LADDER

One (1) Duo Safety 1225A 35' NFPA compliant three section aluminum extension ladder shall be provided and mounted.

DUO SAFETY 24' 2-SECTION ALUMINUM LADDER

One (1) Duo Safety 900A 24' NFPA compliant two section aluminum extension ladder provided and mounted.

DUO SAFETY 16' ALUMINUM ROOF LADDER

One (1) Duo Safety model 875A 16' NFPA compliant aluminum roof ladder with folding hooks provided and mounted.

DUO SAFETY 10' ALUMINUM FOLDING ATTIC LADDER

One (1) Duo Safety 585A 10' NFPA compliant aluminum folding attic ladder shall be provided and mounted.

DRIVER'S SIDE FRONT OF WHEELWELL SPARE CYLINDER COMPARTMENT

A compartment shall be provided in the wheel area in front of the rear axle on the driver's side to hold a total of three (3) spare SCBA cylinders.

The compartment shall be injection molded high strength polyethylene designed specifically for the SCBA cylinder storage. The compartment shall be slanted towards the rear and have a drain port at the low point of the compartment.

DRIVER'S SIDE REAR OF WHEELWELL SPARE CYLINDER COMPARTMENT

A compartment shall be provided in the wheel area behind the rear axle on the driver's side to hold a total of two (2) spare SCBA cylinders.

The compartment shall be injection molded high strength polyethylene designed specifically for the SCBA cylinder storage. The compartment shall be slanted towards the rear and have a drain port at the low point of the compartment.

NOTE: The door for this compartment shall also cover the chassis fuel fill.

PASSENGER'S SIDE FRONT OF WHEELWELL SPARE CYLINDER COMPARTMENT

A compartment shall be provided in the wheel area in front of the rear axle on the passenger's side to hold a total of

Toyne Inc.

three (3) spare SCBA cylinders.

The compartment shall have a drain port at the low point of the compartment.

PASSENGER'S SIDE REAR OF WHEELWELL SPARE CYLINDER COMPARTMENT

A compartment shall be provided in the wheel area behind the rear axle on the passenger's side to hold a total of three (3) spare SCBA cylinders.

The compartment shall be injection molded high strength polyethylene designed specifically for the SCBA cylinder storage. The compartment shall be slanted towards the rear and have a drain port at the low point of the compartment.

WHEELWELL STORAGE COMPARTMENT DOORS – BRUSHED FINISH STAINLESS

Brushed finish stainless steel access doors shall be provided on each wheel well storage compartment in the wheel well.

WHEELWELL SCBA CYLINDER COMPARTMENT RETENTION STRAPS

One 1" wide loop of high visibility yellow webbing shall be installed in each wheel well spare cylinder compartment for each cylinder to be stored in the compartment. The loop(s) shall be designed to loop around the cylinder valve and help prevent the cylinder from sliding out of the compartment if the door is not latched or fails.

FOLD UP ACCESS STEPS - RIGHT SIDE FRONT

Four (4) chrome plated fold up steps shall be provided on front face of the right side compartments. The steps shall support a minimum static load of 500 lbs. and be mounted in accordance to recommended mounting procedures as outlined by NFPA 1901. The steps shall be mounted so as to allow maximum stepping heights to be no more than 18" as per NFPA 1901. The steps shall be a minimum of 6.5" wide x 6.5" depth. The steps shall be attached to the apparatus using stainless steel bolts with self-locking type nuts.

FOLD UP ACCESS STEPS - LEFT SIDE FRONT

Four (4) chrome plated fold up steps shall be provided on front face of the left side compartments. The steps shall support a minimum static load of 500 lbs. and be mounted in accordance to recommended mounting procedures as outlined by NFPA 1901. The steps shall be mounted so as to allow maximum stepping heights to be no more than 18" as per NFPA 1901. The steps shall be a minimum of 6.5" wide x 6.5" depth. The steps shall be attached to the apparatus using stainless steel bolts with self-locking type nuts.

ZICO RL15-2-6 ACCESS LADDER

A Zico model RL15-2-6 access ladder shall be provided on the rear of the apparatus to access the aerial turn table.

The ladder hand rails shall be constructed of 1 1/4" heavy wall aluminum extrusions that are covered with a black heat resistant power coated finish. Each step shall have a flat non-skid surface that is 3" deep x 15 1/2" wide. The lower section of the ladder containing the bottom two steps shall swing out and down.

Toyne Inc.

ACCESS LADDER LEFT SIDE MOUNTING

The rear access ladder shall be mounted on the left (driver) side of the apparatus.

INTERMEDIATE HOSEBED STEP

A full width aluminum treadbrite step shall be provided on the rear face of the apparatus. The step assembly shall be bolted into place using stainless steel fasteners.

NFPA 1901 CERTIFIED 12 VOLT ELECTRICAL SYSTEM

The 12-volt apparatus body electrical system shall be provided and shall be in compliance with NFPA 1901 testing and certification procedures as follows:

NFPA MINIMUM ELECTRICAL LOAD DEFINITION

The NFPA 1901 defined minimum electrical load shall consist of the total amperage required to simultaneously operate the following in a stationary mode:

- Propulsion engine and transmission.
- The clearance and marker lights.
- Communication equipment (5 amp default).
- Illumination of all walking surfaces, the ground at all egress points, control and instrumentation panels and 50% of total compartment lighting.
- Minimum warning lights required for "blocking right of way" mode.
- The current to simultaneously operate and fire pump and all specified electrical devices.
- Anything defined by the purchaser, in the advertised specifications, to be critical to the mission of the apparatus.

RESERVE CAPACITY TEST

The first electrical test to be performed will be the Reserve Capacity Test. All items listed in NFPA Minimum Load Definition shall be activated with the engine shut off. After 10 minutes of operation, those items shall be deactivated. After deactivation, the battery system shall have ample reserve to start the engine.

ALTERNATOR PERFORMANCE TEST AT IDLE

An "alternator performance test at idle" test shall be completed. The minimum continuous electrical load shall be activated with the engine running at idle speed. When the engine temperature has been stabilized at idle speed, the battery system shall be tested to detect any battery discharge current.

ALTERNATOR PERFORMANCE TEST AT FULL LOAD

An "alternator performance test at full load" test shall be completed. The minimum continuous electrical load shall be activated with the engine running up to the engine manufacturer's governed speed for a 2 hour period.

TEST CONDITIONS

Toyne Inc.

All electrical testing shall be performed with the engine compartment at approximately 200 degrees.

12-VOLT WIRING SYSTEM

All 12-volt electrical wiring shall be SXL cross link rated to carry 125% of the maximum current for which the circuit is protected. The wire shall be of sufficient size so that voltage drop in any electrical device does not exceed 10%. All wiring shall be color, number, and function coded with the number and function being printed every 3" along the entire length of all apparatus body wires (as required by NFPA 1901). All wiring shall be routed through heavy duty PVC split loom securely attached and protected against heat, oil, and physical damage. All locations where the wire passes through a body panel shall be protected with electrical grommets.

All connections shall be made using mechanical connectors and be screwed to terminal or junction box with machine screws. Wire nut, insulation displacement, or piercing connections shall not be used.

All circuits shall be provided with properly rated low voltage over current protective devices of the automatic reset type.

Removable access panels shall be provided to provide access to the wire and electrical components.

MULTI-PLEXED ELECTRICAL SYSTEM

The apparatus body electrical system shall incorporate a Multiplexed Electrical System. The multiplex system shall consist of all solid-state components contained inside aluminum extrusions referred to as nodes. Each node shall consist of (24) output channels and (24) input channels. All inputs and outputs will be configured into an electrical harness utilizing Deutsch connectors. The nodes must be waterproof and not require special mounting requirements.

The system, at a minimum, shall be capable of performing the following functions: load management sequencing, switch loads, receive digital and analog signals, perform and report diagnostics, continuously report vehicle status and the system is expandable.

Placement of nodes throughout the apparatus enables a reduction in wire harness bundles, elimination of redundant harnesses and separate circuit boards, relay and circuit breakers, electrical hardware, separate electrical or interlock subsystems and associated electronics for controlling various electrical loads and inputs. The multiplex system shall be field re-programmable and re-configurable by any authorized dealer or service center. This complete system shall eliminate the need for the following separate components or devices: load manager, load sequencer, warning lamp flasher, door open notification system, interlock modules, separate volt meter and ammeter.

The Base System Shall Include:

- Total Load Management
- Load Shedding Capabilities
- Load Sequencing Capabilities
- "On-Board" Diagnostics Readout
- Very Reliable, Solid-State Hardware
- Error Reporting
- Continuous system monitoring and reporting
- Emergency warning lamp flasher
- Door Ajar System

Toyne Inc.

- Field Configurable
- Expandability Capabilities
- Advanced PC Diagnostics

As-built wiring harness drawings and a master circuit list of electrical circuits that the apparatus builder installs shall be furnished in the delivery manuals. These schematics must show the electrical system broken down into separate functions, or small groups of related functions. Schematics shall depict circuit numbers, electrical components, harnesses, and connectors from beginning to end. **A single drawing for all electrical circuits installed by the apparatus builder shall not be accepted.**

VMUX WARRANTY

The VMUX multiplexed electrical system shall be warranted, under normal use and service, for a period of four years. One year parts and labor and the remaining three years parts only.

AUTOMATIC HIGH IDLE FUNCTION

An automatic high idle system shall be installed and will activate whenever the system voltage drops below a determined voltage. The high idle will remain on until adequate voltage is achieved.

REAR LICENSE PLATE LIGHT/BRACKET

A chrome plated LED license plate light shall be provided on the rear of the apparatus.

A license plate mounting bracket shall be provided that spaces the license plate away from the apparatus body.

CLEARANCE LIGHTS/REFLECTORS

All apparatus body clearance lights shall be LED style. All lower clearance lights and reflectors shall be mounted in a manner that provides protection from damage, and shall comply with FMVSS-108 regulations.

MID-MOUNTED SIDE TURN SIGNAL - LED

An amber LED side turn signal shall be provided in the mid-section area of the apparatus on both sides.

LED PUMP COMPARTMENT LIGHTS (2)

Two LED compartment lights shall be provided to illuminate the pump compartment. The lights shall function with the pump operators gauge panel lights.

DUAL TRACK TYPE LED COMPARTMENT LIGHTING

Each apparatus body compartment shall have two track type LED lights vertically mounted in the compartment. The lights shall be constructed of an unbreakable type clear poly type flexible material housed in an aluminum extrusion.

A compartment that is considered a 'full height' compartment shall each have two 48" long light sections and a 'low

Toyne Inc.

height' or above wheel compartment shall each have two 18" long sections.

The lights shall function automatically and independently of other compartments when the compartment door is opened. **Compartment lighting systems that are controlled by a single, dash mounted switch are not acceptable.**

COMPARTMENT LIGHT SWITCHES

Each hinged apparatus body door compartment shall have a magnetic style reed indicator switch.

Each roll up door shall have an integral door open indicator magnet in the lift bar. If the bar is not properly closed, it shall activate the "Door Open" light in the cab.

The compartment lights shall function automatically when the door is opened. A master compartment light switch shall not be acceptable.

DOOR AJAR INDICATOR

The apparatus body door ajar warning system shall be connected to the chassis door ajar indicator system.

LED PERIMETER GROUND LIGHTING -three (3)

There shall be three (3) LED perimeter ground lights furnished and installed on the apparatus body. The lights shall have an unbreakable polycarbonate lens and housing. The lights shall be sealed to help prevent moisture entry.

The ground lights shall be activated with the parking brake.

NOTE: Chassis ground lighting is listed in the chassis section of this specification.

LED APPARATUS BODY STEP LIGHTING

All apparatus body and pump steps and running boards shall be illuminated using chrome plated or stainless steel LED lights. The lights shall function automatically with the park brake.

GROUND/STEP LIGHTING CUTOFF SWITCH

A ground/step light cut off switch shall be provided in the cab to allow the driver to disable the ground lights and other lights that activate when the parking brake is set. The switch shall automatically re-set itself when the parking brake is released.

WHELEN C6 TRI-CLUSTER TAILLIGHTS - LED

Whelen C6BTT LED taillights, C6T LED turn signals and a C6BU clear LED backup lights shall be provided.

A PLASC3V chrome plated trim housing shall be provided, one each side for mounting the tail lights, turn signal lights, and backup lights.

Toyne Inc.

BACKUP LIGHTS PARK FUNCTION

The backup lights shall automatically activate when the park brake is set to provide work lighting at the rear of the apparatus.

ZONE A UPPER WARNING LIGHTING

The lightbar shall be provided on the chassis. Specifications for the lightbar are listed in the chassis specifications.

ZONES C, B, & D UPPER WARNING LIGHTING

Zone C Rear Upper Lighting

Two Whelen model RB6PAP beacons shall be provided one on each side on the rear. Both sides shall be amber.

Zone B Right Side Upper Lighting

This area shall be covered by the outboard rotator of the lightbar in Zone A upper lighting and the RB6PAP beacon in Zone C rear upper lighting.

Zone D Left Side Upper Lighting

This area shall be covered by the outboard rotator of the lightbar in Zone A upper lighting and the RB6PAP beacon in Zone C rear upper lighting.

SIDE FACING LOWER REAR WARNING LIGHTS

One Whelen model M6R red LED light shall be provided shall be provided on each side of the apparatus as low and as far rearward as possible on the apparatus. A chrome bezel shall be provided around the lights.

REAR FACING LOWER WARNING LIGHTS

Two Whelen model M6R red LED lights shall be provided on the lower rear of the apparatus. A chrome bezel shall be provided around the lights.

WHELEN TAL65 TRAFFIC ADVISOR

A Whelen TAL65 36" 6 lamp LED directional traffic advisor shall be provided and mounted on the rear of the apparatus. The advisor shall be subject to load management shedding to comply with NFPA 1901.

DIRECTIONAL LIGHT MOUNTING - INTERMEDIATE STEP

Toyne Inc.

The arrowstick/advisor shall be either recessed into or mounted under the rear intermediate step.

LED HOSE BED LIGHT

One LED light shall be provided and mounted in the front of the hose bed .

The light shall be controlled by the pump panel light switch.

HARRISON 10.0 KW PTO/HYDRAULIC GENERATOR

A Harrison model 10.0MAS-16R4A 10.0 kw PTO/hydraulic powered generator shall be provided and mounted to manufacturers recommendations.

The generator shall be 120/240 volts AC (84/42 amps), single phase, rated at 10,000 watts. The generator shall produce its constant rated electric power output between 950-3300 revolutions per minute engine speed with less than .25 Hz deviation. Except where superseded by the requirements of NFPA 1901, all components, equipment, and installation procedures shall conform to NFPA 70, National Electric Code, (NEC).

Line voltage electrical system equipment and materials included on the apparatus shall be listed and installed in accordance with the manufacturer's instructions. All products shall be used only in the manner for which they have been listed. All power source system mechanical and electrical components shall be sized to support the continuous duty nameplate rating of the power source.

HYDRAULIC FLUID RESERVOIR

A 2 to 3 gallon reservoir shall be provided and mounted in area above the system to allow gravity flow of hydraulic fluid to the system and allow easy filling of the reservoir. The reservoir shall have a replaceable filter that is easily accessible.

HYDRAULIC GENERATOR START SWITCH – CAB CONSOLE

The hydraulic generator start/stop control shall be located on the cab console. The activation switch shall include an integrated indicator light that illuminates when the generator is running.

HYDRAULIC GENERATOR PTO - "HOT SHIFT" TYPE

The generator shall be powered by a Chelsea or Muncie "Hot Shift" type PTO. A lighted and guarded switch shall be provided on the control console that electrically engages/disengages the PTO.

HYDRAULIC GENERATOR MOUNTING

The generator shall be mounted in the forward area of the hose bed properly protected and ventilated to prevent overheat. A front hose bed bulkhead shall also be provided.

GROUNDING

Toyne Inc.

Grounding shall be in accordance with Section 250-6 "Portable and Vehicle Mounted Generators" of the NEC. Ungrounded systems shall not be used. Only stranded or braided copper conductors shall be used for grounding and bonding. An equipment grounding means shall be provided in accordance with Section 250-91 (Grounding Conductor Material) of the NEC. The grounded current carrying conductor (neutral) shall be insulated from the equipment grounding conductors and from the equipment enclosures and other grounded parts. The neutral conductor shall be colored white or gray in accordance with Section 200-6 (Means of Identifying Grounding Conductors) of the NEC.

In addition to the bonding required for the low voltage return current, each body and driving or crew compartment enclosure shall be bonded to the vehicle frame by a copper conductor. This conductor shall have a minimum amperage rating of 115 percent of the nameplate current rating of the source specification label as defined in Section 310-15 (amp capacities) of the NEC. A single conductor properly sized to meet the low voltage and line voltage requirements shall be permitted to be used.

MAIN OVERCURRENT PROTECTION DEVICE

A main overcurrent protection device shall be provided on the generator. The device shall be factory installed by the generator manufacturer.

WIRING METHODS

All fixed wiring systems shall be either metallic or nonmetallic liquid tight conduit or shall be type SO or SEO with a WA suffix, rated at 600 volts at not less than 194 degrees Fahrenheit.

Electrical cord or conduit shall not be attached to chassis suspension components, water or fuel lines, air or air brake lines, fire pump piping, hydraulic lines, exhaust system components or low voltage wiring.

All wiring shall be separated by a minimum of 12", or properly shielded, from exhaust piping and shall be separated from any fuel lines by a minimum of 6".

Electrical cord or conduit shall be supported within 6" of any junction box and at a minimum of every 24" of continuous run. Supports shall be made of nonmetallic materials or corrosion protected metal. All supports shall be of a design that does not cut or abrade the conduit or cable and shall be mechanically fastened to the vehicle.

BREAKER PANEL BOARD

Each individual circuit that is to be powered by the generator shall have a branch circuit overcurrent protection device (circuit breaker). The device shall be sized at not less than 15 amps in accordance with Section 240-3 (Protection of Conductors) of the NEC. If more than 6 individual branch circuits are required on the apparatus, the panel board shall have a main breaker. The panel board shall be readily visible and located so that there is unimpeded access to the panel board controls.

All line voltage conductors located in the main panel board shall be individually and permanently identified. The identification shall reference the wiring schematic or indicate the final termination point. When pre-wiring for future power sources or devices, the unterminated ends shall be labeled showing its function and wire size.

LOAD BALANCING

Toyne Inc.

The breaker panel shall be load balanced to allow the most efficient distribution of the AC load as possible.

BREAKER PANEL LOCATION

The breaker panel shall be located on the lower front wall of the driver's side compartment ahead of the rear wheels.

FROG DISPLAY

There shall be a FROG D provided with the generator. The FROG D shall automatically sense a generator signal and begin displaying information. The digital meter display shall constantly monitor and display voltage, frequency (accurate to within 1 decimal point) and current draw on two separate lines. The display shall be capable of displaying total accumulated run time hours when the MODE button is pressed.

The FROG meter shall be located adjacent to or below the breaker panel.

AKRON ELECTRIC REWIND CORD REEL

There shall be one (1) Akron model ERWC10-16 electric rewind cord reel(s) provided and properly mounted. The reel(s) shall be wired to the electrical panel board through flexible PVC conduit. An individual breaker shall be provided at the panel for the reel. A momentary push button switch shall be provided and mounted in close proximity to the reel for activating the electric rewind. The switch shall be labeled "CORD REEL REWIND".

CORD REEL MOUNTING LOCATION

The cord reel shall be mounted in the _____ compartment with access provided by opening the compartment doors.

150' 12/3 SEOW-A ELECTRICAL CABLE

There shall be a continuous 150' length of 12/3 SEOW-A electrical cable provided on the reel(s). The cable shall be rated at 600 volts at 194 degrees.

YELLOW ELECTRICAL CABLE

The electrical cable on the cord reel(s) shall be yellow.

AKRON BRASS EJBX LIGHTED JUNCTION BOX

There shall be one (1) Akron Brass EJBX lighted junction box(es) provided. The box shall be 120 volt single circuit and have a large handle shall be provided on the top of the box to allow a gloved firefighter to carry the box with ease.

The box shall provide lighting around the box in accordance with NFPA 1901. The box shall be designed to keep the exterior electrical components above 2" of standing water and shall be listed for use in wet locations.

The junction box shall hard wired to the cord. A strain relief shall be provided to protect the cord.

Position #1 shall have a 5-20 GFCI duplex 20 amp 120 volt outlet. (BK-1).

Toyne Inc.

Position #2 shall have a 5-20 duplex 20 amp 120 volt outlet. (229-R/D).

Position #3 shall have a L5-20P single 20 amp twist-lock 120 volt outlet. (224-R).

Position #4 shall have a L5-20P single 20 amp twist-lock 120 volt outlet. (224-R).

The junction box shall be standard gray color.

The receptacle covers shall be standard gray.

JUNCTION BOX HOLDER

An aluminum treadbrite bracket shall be provided to hold the cord reel junction box.

CORD REEL ROLLER ASSEMBLY WITH BALL STOP

A roller assembly with ball stop shall be provided for the cord reel(s). The assembly shall be mounted in a location that will help deflect the cable/hose from the surfaces adjacent to the reel.

FIRE HELMET MOUNTINGS

Fire helmets will be stored in an exterior compartment and will not be carried in the apparatus cab.

PAINT PROCEDURE - PPG DELFLEET BASE COAT/CLEAR COAT

The apparatus body shall remain its natural # 4 brushed stainless steel finish. No paint shall be applied to the apparatus body.

Masking or taping off of any portion of the apparatus during the paint process shall not be acceptable. All compartment doors that are to be painted shall be painted separate from the apparatus body.

All seams or flanges on the apparatus body shall be caulked or properly sealed to prevent moisture accumulation in flanged areas.

PPG CERTIFIED 10 YEAR LIMITED PAINT WARRANTY

The apparatus body exterior finish paint shall have a 10 year limited warranty. The warranty shall be certified by the manufacturer of the paint. Documentation of this shall be provided to the end user. Any warranty that is extended by the apparatus manufacturer and not backed by the paint manufacturer will not be acceptable.

PPG Commercial OEM Product Warranty Coverage:

Warranty Inclusions:

Toyne Inc.

- Delamination of the topcoat and/or other layers of paint.
- Cracking or checking due to failure of the product.
- Excessive loss of gloss caused by cracking, checking and hazing.

Warranty Exclusions:

- Paint deterioration caused by blisters, bubbles, flaking or other degradation due to rust or corrosion originating from the substrate.
- Hazing, chalking or loss of gloss caused by improper care, abrasive polishes, cleaning agents, heavy-duty pressure washing, or aggressive mechanical wash systems.
- Paint deterioration caused by abuse, scratches, chips, gloss reduction, accidents, acid rain, chemical fallout, road treatment materials/chemicals or acts of nature.
- Any paint that was not applied by Toyne, Inc.
- Claims presented without proper Warranty documentation.
- Failure on finishes performed by Non-PPG Commercial Certified Technicians.
- Failure on finishes due to inadequate film builds.
- Failures due to improper cleaning or surface preparation or failure to follow the product use instructions.

THESE ARE THE ONLY WARRANTIES THAT PPG MAKES, AND ALL OTHER EXPRESSED OR IMPLIED WARRANTIES, INCLUDING WITHOUT LIMITATIONS, ANY WARRANTY OF FITNESS FOR PARTICULAR PURPOSE OR USE, ARE DISCLAIMED BY PPG.

ELECTROLYSIS CORROSION CONTROL

The apparatus shall be assembled using ECK or electrolysis corrosion control, on all high corrosion potential areas, such as door latches, door hinges, trim plates, fenderettes, etc. This coating is a high zinc compound that shall act as a sacrificial barrier to help minimize electrolysis and corrosion between dissimilar metals. This shall be in addition to any other barrier material that may be used.

APPARATUS BODY UNDERCOATING

The apparatus body shall be undercoated after assembly is completed. A bituminous based automotive type undercoat shall be used. Care shall be taken to avoid undercoat application to items that would hinder normal maintenance.

COMPARTMENT INTERIORS - BRUSHED STAINLESS FINISH

The compartment interiors shall be brushed stainless steel # 4 finish. The brushed finish shall be as provided by the manufacturer of the material.

Interiors with any type of paint, sprayed-on coatings, DA finish, or standard "mill finish" will not be acceptable.

LETTERING

The Fire Department shall provide and install all vehicle lettering and numbering.

Toyne Inc.

1"-6"-1" NFPA REFLECTIVE STRIPE

A 6" reflective stripe shall be applied to the apparatus.

A 1" gap shall be provided on both the top and bottom of the 6" stripe followed by a 1" reflective stripe above and below the upper and lower gap.

A single 6" stripe shall be applied to the front if space does not permit for the 3 stripe pattern.

The striping shall be applied to a minimum of 50% of the length of the apparatus on each side and 25% across the front of the apparatus. The stripe shall comply with NFPA 1901 requirements.

PRIMARY REFLECTIVE STRIPE COLOR - WHITE

The primary reflective stripe shall be 680-10 white.

SECONDARY UPPER REFLECTIVE STRIPE COLOR - WHITE

The secondary upper reflective stripe shall be 680-10 white.

SECONDARY LOWER REFLECTIVE STRIPE COLOR - WHITE

The secondary lower reflective stripe shall be 680-10 white.

REFLECTIVE STRIPE - HORIZONTAL

The reflective stripe shall be applied in a straight horizontal line from front to rear. The height of the stripe on the chassis cab and the body shall be as close as possible.

REAR CHEVRON STRIPING

A minimum of 50 percent of the rear vertical surface of the apparatus shall be covered with 6 inch alternating red and fluorescent yellow green retro-reflective striping. The striping shall slope downward away from the centerline of the apparatus at a 45-degree angle.

The retro-reflective material shall conform to the requirements of ASTM D 4956 "Standard Specification for Retro-Reflective Sheeting for Traffic Control", Type I or better.

FUEL TANK ACCESS

A removable panel shall be provided on the rear of the apparatus for maintenance access to the top of the fuel tank.

ENGINE HORIZONTAL EXHAUST

Toyne Inc.

Shielding shall be provided between the apparatus body and the exhaust pipe if necessary to deflect heat away from the body. The exhaust system shall be designed and installed to comply with EPA equipment requirements and shall not be modified.

LEFT (DRIVER'S) SIDE FUEL FILL DOOR

A chassis fuel fill shall be located in the driver's side rear wheel well. The fill shall be located behind a brushed stainless steel hinged door with flush latch. The fuel fill shall be properly vented.

REAR MUD FLAPS

Heavy duty black rubber mud flaps shall be provided on the rear wheels. The mud flaps shall be attached to the apparatus in the rear wheel well area using heavy duty stainless steel retention straps that are secured into place using stainless steel fasteners.

FRAME RAIL TOW EYES - CHROME PLATED

Two 3/4" chrome plated steel tow eyes shall be attached direct to the end of the frame rails on the rear of the apparatus. The eyes shall have a minimum of a 3" diameter pass through. Each eye shall be attached to the frame rail with a minimum of four 3/4" hardened steel bolts with locking nuts.

BATTERY DANGERS LABEL - FAMA01

A permanent label shall be provided near the battery location that warns of potential injury or death that could be caused by the batteries. The label shall also state precautions that should be taken while working on or around the batteries.

ROTATING SHAFTS DANGER LABEL - FAMA02

A permanent label shall be provided on each side of the frame rail and in any other location(s) where rotating shaft hazards are apparent. The label shall warn of potential injury or death that could be caused by the movement of the shaft(s) as well as precautions that should be taken while working on or around them.

HOT SURFACE DANGERS LABEL - FAMA03

A permanent label shall be provided near any hot surface that warns of potential injury or death that could be caused by contact with the surface. The label shall also state precautions that should be taken while working on or around the surface.

HOT EXHAUST DANGERS LABEL - FAMA04

A permanent label shall be provided near any hot exhaust surface that warns of potential injury or death that could be caused by contact with the surface. The label shall also state precautions that should be taken while working on or around the surface.

Toyne Inc.

SPINNING ENGINE FAN DANGER LABEL - FAMA05

A permanent label shall be provided on both sides of the engine fan. The label shall warn of potential injury or death that could be caused by the movement of the fan as well as precautions that should be taken while working on or around them.

SEATED AND BELTED WARNING LABEL - FAMA07

A permanent label shall be provided that is visible to all occupants that states that they should be seated and belted while the apparatus is in motion. The label shall also state potential injuries or death that could be caused if the safety belts are not used properly.

AIR CONDITIONING REFRIGERANT WARNING LABEL - FAMA09

If the apparatus is equipped with any type of air conditioning system, a permanent label shall be provided that is located in an area that would be visible to service personnel. The label shall state that the system contains R134A, the necessary precautions that should be taken and the dangers of working on or around the system.

CAB INTERIOR EQUIPMENT MOUNTING DANGER LABEL - FAMA10

A permanent label shall be provided inside of the cab warning of the dangers of unsecured equipment inside the cab. The label shall state that all equipment shall be properly secured and also warn of potential injury or death that could be caused by failing to do so.

SCBA SEAT DANGER LABEL - FAMA11

If the apparatus is equipped with SCBA seats in the cab, a permanent label shall be provided inside of the cab warning of the dangers of using the seat without the SCBA properly secured or seat insert in place. The label shall warn of potential injury or death that could be caused by improper use of the seat.

FIRE SERVICE TIRE RATING LABEL - FAMA12

A permanent label shall be provided inside of the cab in view of the driver while entering the cab warning of the dangers of improper use of the tires on the apparatus. The label shall also warn of potential injury or death that could be caused by improper tire use or condition.

ELECTRONIC STABILITY CONTROL LABEL - FAMA13

If the apparatus is equipped with an electronic stability control system, a permanent label shall be provided inside of the cab in view of the driver warning of the dangers of improper operation of the apparatus and the importance of safe driving. The label shall also warn of potential injury or death that could be caused by improper operation of the apparatus.

MAXIMUM OCCUPANCY LABEL - FAMA14

Toyne Inc.

A permanent label shall be provided inside of the cab in view of the driver stating the maximum number of personnel that can ride in the apparatus. The label shall also warn of potential injury or death that could be caused by exceeding the stated capacity.

DO NOT WEAR HELMET LABEL - FAMA15

A permanent label shall be provided inside of the cab in view of all seated positions stating that helmets should not be worn in cab. The label shall also warn of potential injury or death that could be caused by wearing helmet in cab.

VEHICLE BACKING LABEL - FAMA17

A permanent label shall be provided inside of the cab in view of the driver advising of proper procedures to following when the apparatus is in reverse motion. The label shall also warn of potential injury or death that be caused by failing to follow proper procedures.

INTAKE/DISCHARGE CAP PRESSURE LABEL - FAMA18

A permanent label shall be provided in all areas that intakes and discharges are capped. The label shall give instruction on how to properly remove the cap. The label shall also warn of potential dangers, injury or death that be caused by failing to follow proper cap removal procedures.

HOSE RESTRAINT LABEL - FAMA22

A permanent label shall be provided near any hose storage area. The label shall instruct the operator to insure that all hose is properly secured prior to placing the apparatus in motion and to provide warning of potential dangers, including injury or death, in failing to do so.

ACCESS STEPS/LADDER LABEL - FAMA23

A permanent label shall be provided at any area of the apparatus where personnel will be boarding or exiting the apparatus. The label shall instruct the operator in the proper method of climbing into or onto the apparatus as well as exiting and provide indication of potential injury or death that could occur in failing to do so.

TRAINED OPERATOR ONLY LABEL - FAMA25

A permanent label shall be provided on the pump panel that states that only properly trained personnel should operate the apparatus and shall indicate that injury or death could occur as a result.

TRAINED OPERATOR ONLY LABEL - FAMA25

A permanent label shall be provided on the aerial control panel that states that only properly trained personnel should operate the apparatus and shall indicate that injury or death could occur as a result.

NOT A STEP WARNING LABEL - FAMA26

A permanent label shall be provided in any horizontal location that a firefighter may feel tempted to use as a step but is not designed, constructed or intended to be a stepping, standing or walking surface. The label shall state that the surface is not intended for this purpose and indicate potential injury or death in doing so.

Toyne Inc.

COMPARTMENT TOP WARNING LABEL - FAMA26

A permanent label shall be provided on the front and rear of the compartment tops on both sides warning that the area is not designed, constructed or intended to be a stepping, standing or walking surface. The label shall state that the surface is not intended for this purpose and indicate potential injury or death in doing so.

FRONT BUMPER EXTENSION WARNING LABEL - FAMA26

A permanent label shall be provided on the front bumper extension warning that the area is not designed, constructed or intended to be a stepping, standing or walking surface. The label shall state that the surface is not intended for this purpose and indicate potential injury or death in doing so.

BREAKER PANEL WARNING LABEL - FAMA27

A permanent label shall be provided on the breaker panel. The label shall warn of electrical shock hazards, proper service procedures and indicate potential injury or death due to improper use and service.

HYDRAULIC HIGH PRESSURE LEAKS WARNING LABEL - FAMA29

If the apparatus is equipped with any component(s) that are powered by high hydraulic pressure, a permanent label shall be provided near the majority of all hydraulic lines and components.

The label shall warn of potential injury or death that could occur when working on or around any hydraulic component or hose and provide basic safety precautions that should be taken when doing so.

STABILIZER CRUSH WARNING LABEL - FAMA30

A permanent label shall be provided near each stabilizer and at the stabilizer control area warning of potential injury or death that could be caused by the stabilizer. The label shall also indicate safety precautions that should be taken while operating or working around the stabilizer.

STABILIZER PINS AND PADS WARNING LABEL - FAMA31

A permanent label shall be provided at the stabilizer control area warning of potential injury or death that could be caused by the improper use of or failing to use stabilizer pins and pads as well as safety precautions that should be taken when deploying the stabilizers.

STABILIZER PADS WARNING LABEL - FAMA32

A permanent label shall be provided at the stabilizer control area warning of potential injury or death that could be caused by the improper use of or failing to use stabilizer pads as well as safety precautions that should be taken when deploying the stabilizers.

STABILIZERS NOT EXTENDED WARNING LABEL - FAMA33

A permanent label shall be provided adjacent to the 'stabilizer not extended' warning light stating that the stabilizers are not fully extended.

Toyne Inc.

FALL RESTRAINT/SAFETY HARNESS WARNING LABEL - FAMA34

A permanent label shall be provided at the base as well as the ladder tip warning of potential injury or death that could be caused by not using a safety harness and restraint belt not properly attached to the device.

AERIAL ELECTROCUTION WARNING LABEL - FAMA35

A permanent label shall be provided at the base at the aerial control location(s) and pump panel (if apparatus is equipped with a pump) warning of potential injury or death that could be caused by coming into or operating in the area, of power lines and related equipment. The label shall also state safety precautions that should be taken while operating around power lines.

AERIAL ELECTROCUTION WARNING LABEL - FAMA36

A permanent label shall be provided on both sides and rear of the apparatus warning of potential injury or death that could be caused by coming into or operating in the area, of power lines and related equipment. The label shall also state safety precautions that should be taken while operating around power lines.

AERIAL DEVICE LOAD CAPACITY WARNING LABEL - FAMA37

A permanent label shall be provided at the turn table, in the platform (if applicable) and at tip control (if applicable) warning of potential injury or death that could be caused by exceeding rated load capacity of the device. The label shall also state safety precautions relating to wind, ice and surface stability.

AERIAL LADDER RUNG PINCH WARNING LABEL - FAMA38

A permanent label shall be provided at any aerial control location warning of potential injury or death that could be caused by movement of the ladder rungs. The label shall also state safety precautions relating hand and feet placement on the rungs.

AERIAL INSPECTION LABEL - FAMA39

A permanent label shall be provided at the turn table control location warning of potential injury or death that could be caused by failing to follow the instruction manual and inspection/maintenance schedules.

FALL PROTECTION ANCHOR LABEL - FAMA40

A permanent label shall be provided adjacent to any fall protection anchor. The label shall serve as a reminder to properly connect to the anchor.

CAB TILT WARNING LABEL - FAMA41

A permanent label shall be provided inside the driver's door warning of potential injury or death that could be received in the area under or around a tilted cab. The label shall also state safety precautions that should be taken when the cab is tilted.

SIREN NOISE WARNING LABEL - FAMA42

Toyne Inc.

A permanent label shall be provided inside the driver's door warning of potential injury that could be received from the noise of the siren. The label shall also state safety precautions that should be taken when the siren is in use.

AERIAL DEVICE OPERATOR ATTENTION LABEL - FAMA47

A permanent label shall be provided at the turn table control panel and tip controls/platform (if applicable) on the pump panel that states that only properly trained personnel should operate the apparatus as well as notice to discontinue use and remove personnel from device in dangerous conditions. The label shall also warn of potential injury or death if proper rules are not followed.

FLUID CAPACITY LABEL

A permanent plate shall be mounted in the driver's compartment specifying the quantity and type of the following fluids used in the apparatus (if applicable) for normal maintenance:

- Engine oil.
- Engine coolant.
- Chassis transmission fluid.
- Pump transmission fluid.
- Pump primer fluid.
- Drive axle fluid.
- Air conditioning refrigerant.
- Air conditioning lubrication oil.
- Power steering fluid.
- Cab-tilt mechanism fluid (if applicable).
- Transfer case fluid.
- Equipment rack fluid.
- CAFS compressor system lubricant.
- Generator system lubricant.
- Front tire cold pressure.
- Rear tire cold pressure.
- Maximum tire speed ratings.

LENGTH, HEIGHT, WEIGHT LABEL

A permanent plate or label shall be provided in the cab stating the overall length, height and the gross vehicle weight rating (GVWR), in tons, of the completed apparatus.

The wording on this label shall indicate that the information on the plate/label was current at the time of manufacture and if the overall height of the apparatus changes while the vehicle is in service, the purchaser shall revise the height dimension on the plate.

POWER SOURCE SPECIFICATION LABEL - NFPA

A label shall be permanently attached to the apparatus near the operator's control panel. The label shall provide the operator with the following information:

Operational Category

Continuous Duty Rating

Toyne Inc.

Rated voltage(s) and type (ac or dc)	In watts
Phase	Single or three
Rated frequency (at rated voltage(s))	Hertz
Rated amperage	Amps
Continuous rated watts	Watts
Power source engine speed	RPM

POWER SOURCE INSTRUCTIONAL LABEL - NFPA

A label shall be permanently attached at any location on the apparatus that the AC power source may be activated. The label shall provide the operator with essential power source operating instructions including the power-up and power-down sequence.

CORD REEL INFORMATION LABEL - NFPA

A label shall be permanently attached adjacent to the cord reel displaying the following information:

- Current rating.
- Current type.
- Phase.
- Voltage.
- Total cord length.

PUMP AND AERIAL CERTIFICATIONS

Where applicable, the following documents shall be provided with the completed apparatus:

- Pump manufacturer's certification of suction capability.
- Special condition certifications, if any.
- Pump manufacturer's approval for stationary pumping.
- Engine manufacturer's certified brake horsepower curve showing maximum governed speed.
- Pump manufacturer's certification of hydrostatic test.
- Pump manufacturer's certification of hydrodynamic test, if required.
- Certification of inspection and tests for the fire pump.
- Certification of inspection and tests for the aerial device.
- NFPA 1911 technical information for inspections.

OPTICAL WARNING LIGHT CERTIFICATION

The emergency warning light system shall be certified using one of the available methods provided for in NFPA 1901 13.8.16.

SIREN CERTIFICATION

The siren manufacturer shall certify the siren to NFPA 1901 13.9.1.1.

ELECTRICAL SYSTEM PERFORMANCE CERTIFICATION

Toyne Inc.

A written load analysis and the results of the electrical system performance test shall be provided with the completed apparatus. The load analysis shall include the following:

- Nameplate rating of the alternator.
- The alternator rating under the conditions specified in NFPA 1901 13.3.2.
- Each of the component loads specified in NFPA 1901 13.3.3 that make up the minimum continuous electrical load.
- Additional electrical loads that, when added to the minimum continuous electrical load, determine the total continuous electrical load.
- Each individual intermittent electrical load.

BOOSTER TANK CAPACITY CERTIFICATION

The manufacturer shall certify the capacity of the booster tank. Certification shall be documented on the Manufacturer's Record of Construction document.

CLASS A FOAM TANK CERTIFICATION

Certification of class A foam tank capacity shall be provided.

NPFA SLIP RESISTANCE CERTIFICATION

Any materials used as a stepping, standing or walking surface shall be certified to be compliant with NFPA 1901 15.7.4. Documentation shall be provided with the completed apparatus.

NFPA GENERATOR SYSTEM TESTING

The generator and related electrical components shall be tested to NFPA 1901 22.15 requirements. Documentation of the tests shall be provided with the completed apparatus.

120/240 VOLT ELECTRICAL EQUIPMENT INSTALLATION

All 120/240 volt electrical equipment shall be installed by the apparatus manufacturer. This shall include any item related to the system, including, but not limited to the following:

- Generator.
- All scene lighting accessories.
- All outlets, and cord reels (where applicable)
- Breaker panel.

To maintain the integrity of the entire apparatus electrical system, all 120/240 volt equipment must be installed by the apparatus manufacturer. Installation by the apparatus manufacturer will also allow the electrical system to be NFPA tested during the U.L. pump certification testing procedure.

Installation of any portion of the 120/240 volt system by a dealer or service center will not be acceptable. There shall be no exception to this requirement.

Toyne Inc.

WEIGHT CERTIFICATION

Documents from a certified scale showing actual loading on the front, rear and overall apparatus shall be provided. The apparatus shall be scaled with the water tank full but without personnel, equipment and hose.

VEHICLE ROLLOVER STABILITY

The apparatus chassis shall be equipped with a stability control system and shall be certified to NFPA 1901 Rollover Stability requirements.

UNDERWRITER'S LABORATORIES TESTING

The apparatus shall undergo an Underwriter's Laboratories Aerial with Pump Certification Test to insure that the completed apparatus meets the requirements of NFPA 1901. The certificate shall be provided to the purchaser upon completion. Underwriter's Laboratories shall also perform the required testing on the entire installed electrical system. Self-certification by the apparatus manufacturer will not be acceptable.

MANUFACTURER'S RECORD OF APPARATUS CONSTRUCTION

All information required to comply with NFPA 1901 4.20.1 shall be provided with the completed apparatus.

OPERATIONS AND SERVICE DOCUMENTATION

The apparatus shall be complete with all operation and service documentation covering the apparatus as delivered and accepted. The documentation shall address the inspection, service and operations of the apparatus and all major components as required in NFPA 1901 4.20.2.

"AS BUILT" APPARATUS BODY OWNERS MANUALS (2)

Two "as built" apparatus body owner's manual USB drives shall be provided with the apparatus. All apparatus body electrical schematics shall be provided as well as all instructional and maintenance manuals on components provided and permanently mounted on the apparatus. A copy of the final apparatus body build specifications shall also be included on the drive. The USB shall be "read only" and shall not allow modification.

To eliminate component confusion, generic documentation with equipment that is not provided on the apparatus body shall not be acceptable.

FAMA FIRE APPARATUS SAFETY GUIDE

One (1) FAMA Fire Apparatus Safety Guide(s) shall be provided with the completed apparatus.

STATEMENT OF EXCEPTION - NFPA MISCELLANEOUS REQUIRED EQUIPMENT

The customer shall be responsible for providing all NFPA required miscellaneous equipment that is not contained within these specifications. All required equipment must be properly installed on the apparatus and in working condition prior to the apparatus being placed into service.

Toyne Inc.

FAMILIARIZATION AND DEMONSTRATION

Upon completion of the new apparatus, an authorized properly trained representative of the manufacturer shall perform a "Familiarization and Demonstration" overview of the apparatus and related components.

The Department shall provide the representative with a written list, by full proper names, of the individual(s) that are to receive the overview. Upon completion of the overview, each person in attendance will be required to acknowledge, by signature, that they understand the operation of the apparatus and all related components.

CHASSIS FAMILIARIZATION

Familiarization of the apparatus shall include the following:

- How to locate gauges or indicators and check all fluid levels and operational use of the apparatus.
- How to tilt the chassis cab or hood assembly for access to the engine, fire pump (if applicable), or aerial control (if applicable), or any other device to allow access to fluids or for required maintenance.
- Interior cab controls, instruments, mirrors, safety devices or alarms, brake operations, transmission control, pump controls (if applicable) exhaust regeneration (if applicable), seat adjustments, warning light engagement and other operational equipment.

FIRE PUMP FAMILIARIZATION

Familiarization of the apparatus shall include the following items related to the fire pump system:

- Setting the parking brake, proper transmission gear and the fire pump engagement operations.
- Throttle control.
- Primer and tank-to-pump operation.
- Use of pressure control device.
- Tank refilling operations.
- Proper operation of discharge controls.
- Proper shutdown and draining of the system.

120/240 GENERATOR FAMILIARIZATION

Familiarization of the apparatus shall include the following items related to the generator system:

- Proper engagement (if driven by the chassis).
- Start up, operation and shut down of the generator.
- Monitoring of controls and instruments.

AERIAL SYSTEM FAMILIARIZATION

Familiarization of the apparatus shall include the following items related to the aerial device system:

- Positioning and locating the apparatus for safe operations.
- Chassis parking brakes and engagement of hydraulic system.
- Deployment of stabilization devices and use of ground pads.
- Operation of elevation, extension, and rotation of the aerial device.
- Operation of waterway, nozzle and other firefighting devices.
- Operation and use of breathing air system if applicable.

Toyne Inc.

- Specific aerial device maintenance and service areas for operator's.
- Shutdown and return to service operations.
- Operation of tip/platform controls where applicable.
- General familiarization and demonstration of aerial device.
- Review of all safety devices, interlocks, and operational hazards.

POST ACCEPTANCE TRAINING REQUIREMENTS

After apparatus acceptance, the Department shall be responsible for ongoing training of personnel. The Department shall not allow untrained or undertrained personnel to operate the apparatus or any included feature of the apparatus.

DUO-SAFETY 4FP 4' FIBERGLASS PIKE POLE WITH D HANDLE - two (2)

There shall be two (2) Duo-Safety model 4FP 4' fiberglass pike pole(s) with D handle provided and mounted on the apparatus.

DUO-SAFETY 6FP 6' FIBERGLASS PIKE POLE - two (2)

There shall be two (2) Duo-Safety model 6FP 6' fiberglass pike pole(s) provided and mounted on the apparatus.

DUO-SAFETY 8FP 8' FIBERGLASS PIKE POLE - two (2)

There shall be two (2) Duo-Safety model 8FP 8' fiberglass pike pole provided and mounted on the apparatus.

DUO-SAFETY 12FP 12' FIBERGLASS PIKE POLE - two (2)

There shall be two (2) Duo-Safety model 12FP 12' fiberglass pike pole(s) provided and mounted on the apparatus.